



ТОВ "Компанія "Парк" - офіційний представник в Україні!

+38 (093) 033-33-66
info@parkgroup.com.ua
www.parkgroup.com.ua

V450CM-YES

EN

Heavy Duty Block Cylinder with
Key-way clamping for long strokes

DE

Hydraulikzylinder schwere Ausführung
mit Nutbefestigung für langhub

IT

Cilindri oleodinamici serie pesante con
fissaggio a piedino per corse lunghe

FR

Vérins Hydrauliques Série Lourde avec
fixation par trous verticaux pour courses longues

450
BAR



Cart and Plug Movement
Cart und Plug Bewegung
Movimentazione carrello e spina
Mouvement de chariot et de fiche



Ejection Plate Movement
Auswerferplattenbewegung
Movimentazione piastra di estrazione
Mouvement de la plaque d'éjection

CYLINDERS

CAT. 2022/23.01.V450CM-YES.01

V450CM-YES

EN

ORDER CODE

IT

CODICE ORDINE

DE

BESTELLCODE

FR

CODE COMMANDE

Cylinder Model
Zylinder Modell
Modello cilindro
Modèle du vérin

CM

Bore

Bohrung
Alesaggio
Alésage

050

Clamping Style

Befestigungs Art
Fissaggio
Fixation

D

Oil Ports Type

Art der Anschlüsse
Tipo di orifici
Type d'orifice

O

Oil Ports Position

Lage der Leitungsanschlüsse
Posizione orifici
Position des orifices

E

PAGE SEITE PAGINA PAGE

M6

M8 > M9

M8 > M9

M8 > M9

Øx

050

063

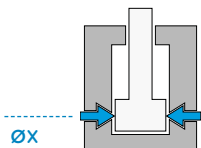
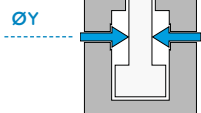

D

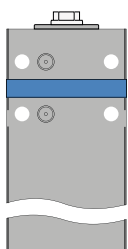

O

Manifold with O-Rings
Ölanschluß durch O-Ringe
Integrati con O-ring
Intégrés avec joint torique

E

Bottom Side (O-Rings)
Seitliche Ölanschlüsse (durch O-Ringe)
Lato inferiore (O-ring)
Dessous (O-rings)

I

Bottom Side (O-Rings), Mirrored
Seitliche Ölanschlüsse (durch O-Ringe),
gespiegelt
Lato inferiore (O-ring), speculare
Dessous (O-rings), en miroir

V450CM-YES

Rod end Type
Kolbenstangen Ausführung
Estremità stelo
Extrémité de la tige

Cylinder Version
Zylinder-Version
Versione cilindro
Version du vérin

Stroke
Hublänge
Corsa
Course

Rod Accessories
Zubehör Kolbenstange
Accessori stelo
Accessoires de la tige

G

#

050

+

MTA20X250

M10

M11

M7

M11

G

Female Metric Thread
Metrisches Innengewinde
Filetto femmina metrico
Taraudage métrique

A

Male Metric Thread
Metrisches Aussengewinde
Filetto maschio metrico
Filetage métrique

I

UNF-UNEF Female Thread
UNF-UNEF Innengewinde
Filetto femmina UNF-UNEF
Taraudage UNF-UNEF

H

UNF-UNEF Male Thread
UNF-UNEF Aussengewinde
Filetto maschio UNF-UNEF
Filetage Male UNF-UNEF

L

Female Metric Thread, Bigger Rod
Metrisches Innengewinde,
größere Kolbenstange
Filetto femmina metrico, stelo maggiorato
Taraudage métrique, tige augmentée

M

Female UNF Thread, Bigger Rod
UNF Innengewinde, größere Kolbenstange
Filetto femmina UNF, stelo maggiorato
Taraudage UNF, tige augmentée

B

Male Metric Thread, Bigger Rod
Metrisches Aussengewinde,
größere Kolbenstange
Filetto maschio metrico, stelo maggiorato
Filetage métrique, tige augmentée

#

Base Cylinder
Grundausführung
Cilindro base
Vérin base

Z

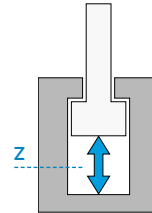

#

None
Ohne
Nessuno
Aucun



MTA

Male Thread
Aussengewinde
Filetto maschio
Filetage

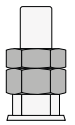

MFA

Floating Joint
Hammerkopf
Testa a martello
Tenon

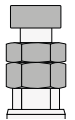

DFA

Floating Joint with Female
Hammerkopf mit Gegenstück
Testa a martello con femmina
Tenon male / femelle

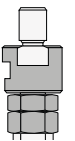

EN

TECHNICAL AND WORKING CHARACTERISTICS CHART

DE

TABELLE TECHNISCHE MERKMALE UND FUNKTION

IT

TABELLA CARATTERISTICHE TECNICHE E DI FUNZIONAMENTO

FR

TABLEAU DES CARACTÉRISTIQUES TECHNIQUES ET DE FONCTIONNEMENT

<p>Maximum Static Pressure Maximaler statischer Druck Pressione massima statica Pression statique maximale</p>	<p>Maximum Nominal Delivery (Pushing) Nennwert Max. Durchflussmenge (beim Ausfahren) Portata massima nominale Débit nominal maximum (en poussée)</p>
<p>Manifold Oil Delivery* Ölanschluß durch O-Ringe* Alimentaz. con O-ring* Alimentation avec O-ring*</p>	

ØX	MPa - (bar) - PSI	l/min
50	25 - (250) - 3626	12
63	25 - (250) - 3626	18

* : Oil delivery with manifold at higher pressures can bring oil leakages from delivery O-rings.

* : Übersteigt der Betriebsdruck die angegebenen Werte, führt dies bei Zylindern mit Anschluss über O-Ringe zum Ölaustritt an den O-Ringen.

* : L'uso dei cilindri con alimentazione integrata a pressioni superiori può provocare perdite di olio dagli O-ring di alimentazione.

* : L'utilisation du vérin avec alimentation intégrée à une pression supérieure peut provoquer une fuite d'huile au niveau des O-rings d'alimentation.

ØX = Bore Bohrung Alésaggio Alésage

<p>Max Mass Applicable at Max Speed Max. bewegbare Masse bei max. Geschwindigkeit. Massa max applicabile alla velocità max Masse maximum applicable à la vitesse maxi</p>	<p>Maximum Piston Speed Maximale Geschwindigkeit des Kolbens Velocità massima pistone Vitesse maximum du vérin</p>	<p>Maximum Working Temperature Max. Betriebstemperatur Temperatura massima esercizio Température max. d'exercice</p>
--	---	---

ØX	Kg	m/s	
50	25	0,1	160 °C 320 °F
63	30		

EN

BORE SIZE AND STROKE

IT

ALESAGGIO E CORSA

DE

KOLBENDURCHMESSER UND HUBLÄNGE

FR

ALÉSAGES ET COURSES

CM

ØX

050

D

O

E

Table for push and pull forces in daN (1 daN = 1 kgf)

Tabelle Druck- und Zugkraft in daN (1 daN=1 kgf)

Tabella forze in spinta e tiro in daN (1 daN = 1 kgf)

Tableau des forces de poussée et de traction en daN (1 daN=1 kgf)

ØX	ØY*				8 MPa 80 bar 1160 PSI		14 MPa 140 bar 2030 PSI		20 MPa 200 bar 2900 PSI		25 MPa 250 bar 3626 PSI	
	A	H	L	M	Th	Tr	Th	Tr	Th	Tr	Th	Tr
	G	I	B									
050	28				1570	1078	2748	1886	3925	2694	4906	3368
		36			1570	756	2748	1323	3925	1890	4906	2363
063	28				2493	2000	4362	3500	6231	5000	7789	6251
		36			2493	1679	4362	2938	6231	4197	7789	5246

*: Depending on rod end (see page M10)

Abhängig von dem Kolbenstangenende (siehe Seite M10)

Dipende dall'estremità stelo (vedi pagina M10)

Dépend de l'extrémité de la tige (voir page M10)

Th Thrust Druck Spinta Poussée

Tr Traction Zug Trazione Traction

ØX Bore Bohrung Alesaggio Alésage

ØY Rod Kolbenstange Stelo Tige

G # Z 050 + MTA20X250

[Standard strokes table in mm](#)

Standard hublängen tabelle in mm

[Tabella corse standard in mm](#)

Tableau des course standards en mm

Z	080	100	120	140	160	180	200
ØX							
50							
63							

V450CM-YES

[Standard strokes](#) [Standard hublängen](#) [Corse standard](#) [Courses standard](#)

NOTES: Stroke tolerance: -0/+0.5 mm. For intermediate strokes, choose the closest longer stroke, and require a stroke reducer (minimum reduction: 8 mm). Option not available for ØX 16. Special strokes can be requested to our Sales Department.

BEMERKUNG: Hub Toleranz -0/+0,5 mm. Für Zwischenhübe nehmen Sie den nächst grösseren Hub und einen Hubbegrenzer (außer Bohring Ø16mm). Für kundenspezifische Hublängen bitte unser Verkaufsbüro kontaktieren.

NOTE: Tolleranza sulla corsa: -0/+0,5 mm. Per corse intermedie considerare la corsa immediatamente superiore e richiedere il riduttore di corsa (riduzione minima: 8 mm). Opzione non disponibile per ØX 16. Si possono richiedere corse speciali contattando il nostro ufficio vendite.

NOTE: Tolérance sur la course: -0/+0,5 mm. Per les courses intermédiaires (pas disponibles pour l'alésage Ø16) considérer la course immédiatement supérieure et demander le réducteur de la course (au minimum 8 mm). Course spéciales disponibles sur demande. Contacter notre bureau commercial.

ØX [Bore](#) [Bohrung](#) [Alesaggio](#) [Alésage](#)

ØY [Rod](#) [Kolbenstange](#) [Stelo](#) [Tige](#)

Z [Stroke](#) [Hub](#) [Corsa](#) [Course](#)

ØX

CM

050

D

O

E

D O E

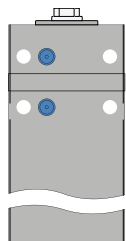

Key-way clamping for long strokes, with inline bottom manifold oil delivery

Nutbefestigung für langhub mit integrierte Anschlüsse über O-Ringe, seitlich

Fissaggio a piedino per corse lunghe, con orifici integrati inferiori allineati

Fixation pour courses longues, par trous verticaux avec orifices intégrés dessous

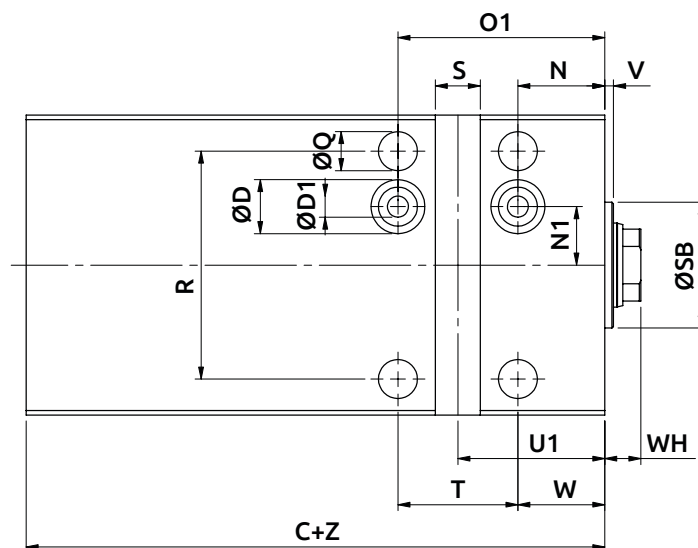
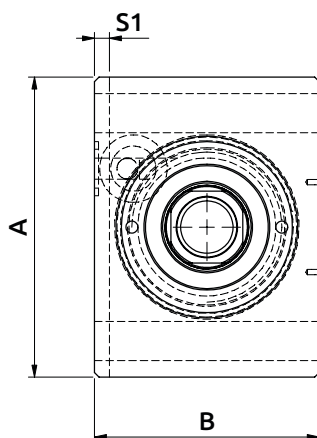

ØD1 : Max. eccentricity 0.5 mm - O-rings included in the supply.
Eccentricità max 0.5 mm - O-ring compresi nella fornitura.

Unmittigkeit: Max. 0,5mm. O-Ringe im Lieferumfang enthalten.
Excentricité maxi 0,5 mm. O-rings inclus dans la livraison.

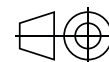

V450CM-YES

ØX	ØY*				A	B	C+	ØD	ØD1	O1	N	N1	ØQ	R	S (H10)	S1	ØSB h9	W	T	U1	V	WH
	A	H	L	M																		
	G	I	B																			
50	28				100	75	73	18	7	69	29	19,5	13	76	15	5	42	29	40	49	3	12
	36																					
63	28	36			108	88	78	18	7	69	29	23,5	13	90	15	5	50	29	40	49	3	13,5

* : Depending on rod end (see page M10) Abhängig von dem Kolbenstangenende (siehe Seite M10)
Dipende dall'estremità stelo (vedi pagina M10) Dépend de l'extrémité de la tige (voir page M10)

NOTES: For dimensions where no tolerance is indicated, refer to DIN norm 7168-m.

ACHTUNG: Für Maße ohne Toleranzangaben gilt DIN 7168-m.

NOTE: Per le dimensioni senza indicazione di tolleranza, riferirsi alla norma DIN 7168-m.

NOTE: Pour les dimensions où la tolerance n'est pas indiquée, adressez-vous aux normes DIN 7168-m.

ØX

Bore Bohrung Alesaggio Alésage

ØY

Rod Kolbenstange Stelo Tige

Z

Stroke Hub Corsa Course

eg. ØX = 50, ØY = 28, Z = 50mm : C + Z = 73 + 50 = 123 mm

Z

G

#

050

+

MTA20X250

DOI

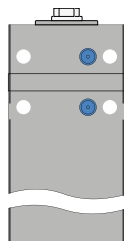

Key-way clamping for long strokes, with inline bottom manifold oil delivery, Mirrored

Nutbefestigung für langhub mit integrierte Anschlüsse über O-Ringe, seitlich, gespiegelt

Fissaggio a piedino per corse lunghe, con orifici integrati inferiori allineati, speculare

Fixation pour courses longues, par trous verticaux avec orifices intégrés dessous, en miroir

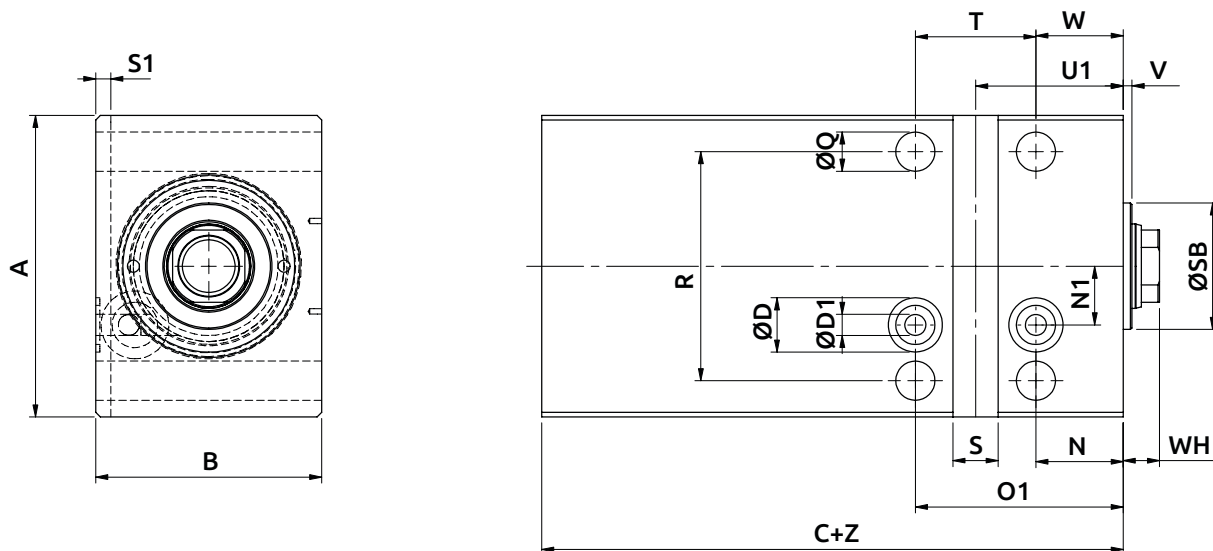

ØD1 : Max. eccentricity 0.5 mm - O-rings included in the supply.
Eccentricità max 0.5 mm - O-ring compresi nella fornitura.

Unmittigkeit: Max. 0,5mm. O-Ringe im Lieferumfang enthalten.
Excentricité maxi 0,5 mm. O-rings inclus dans la livraison.



ØX	ØY*				A	B	C+	ØD	ØD1	O1	N	N1	ØQ	R	S (H10)	S1	ØSB h9	W	T	U1	V	WH
	A	H	L	M																		
	G	I	B																			
50	28				100	75	73	18	7	69	29	19,5	13	76	15	5	42	29	40	49	3	12
	36																					
63	28	36	108	88	78	18	7	69	29	23,5	13	90	15	5	50	29	40	49	3	13,5		

* : Depending on rod end (see page M10) Abhängig von dem Kolbenstangenende (siehe Seite M10)
Dipende dall'estremità stelo (vedi pagina M10) Dépend de l'extrémité de la tige (voir page M10)

NOTES: For dimensions where no tolerance is indicated, refer to DIN norm 7168-m.

ACHTUNG: Für Maße ohne Toleranzangaben gilt DIN 7168-m.

NOTE: Per le dimensioni senza indicazione di tolleranza, riferirsi alla norma DIN 7168-m.

NOTE: Pour les dimensions où la tolerance n'est pas indiquée, adressez-vous aux normes DIN 7168-m.

ØX Bore Bohrung Alesaggio Alésage

ØY Rod Kolbenstange Stelo Tige

Z Stroke Hub Corsa Course

eg. ØX = 50, ØY = 28, Z = 50mm : C + Z = 73 + 50 = 123 mm

EN

CHOICE OF ROD END STYLE

DE

AUSWAHL KOLBENSTANGENENDE

IT

SCELTA DELL' ESTREMITÀ DELLO STELO

FR

CHOIX DE L'EXTRÉMITÉ DE LA TIGE

ØX

CM

050

D

O

E

Description of Rod end Style

Beschreibung des Kolbenstangenendes

Descrizione tipo di estremità

Description du type d'extrémité de la tige

G

Female Metric Thread - standard
 Metrisches Innengewinde - standard
Filetto femmina metrico - standard
 Taraudage métrique - standard

A

Male Metric Thread
 Metrisches Aussengewinde
Filetto maschio metrico
 Filetage métrique

I

UNF-UNEF Female Thread (U.S.A. Standard)
 UNF-UNEF Innengewinde (U.S.A. Standard)
Filetto femmina UNF-UNEF (Standard U.S.A.)
 Taraudage UNF-UNEF (Standard U.S.A.)

H

UNF-UNEF Male Thread (U.S.A. Standard)
 UNF-UNEF Aussengewinde (U.S.A. Standard)
Filetto maschio UNF-UNEF (Standard U.S.A.)
 Filetage Male UNF-UNEF (Standard U.S.A.)

L

Female Metric Thread, Bigger Rod
 Metrisches Innengewinde, größere Kolbenstange
Filetto femmina metrico, stelo maggiorato
 Taraudage métrique, tige augmentée

M

Female UNF Thread (U.S.A. Standard), Bigger Rod
 UNF Innengewinde (U.S.A. Standard), größere Kolbenstange
Filetto femmina UNF (Standard U.S.A.), stelo maggiorato
 Taraudage UNF (Standard U.S.A.), tige augmentée

B

Male Metric Thread, Bigger Rod
 Metrisches Aussengewinde, größere Kolbenstange
Filetto maschio metrico, stelo maggiorato
 Filetage métrique, tige augmentée

A / H / B

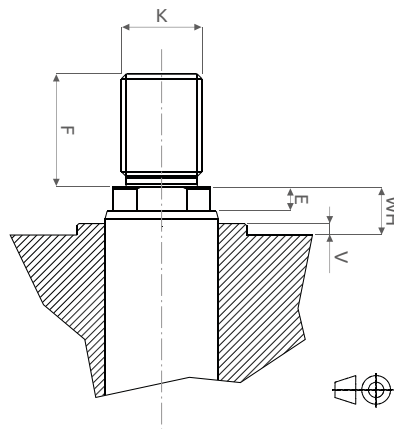

G / I / L / M

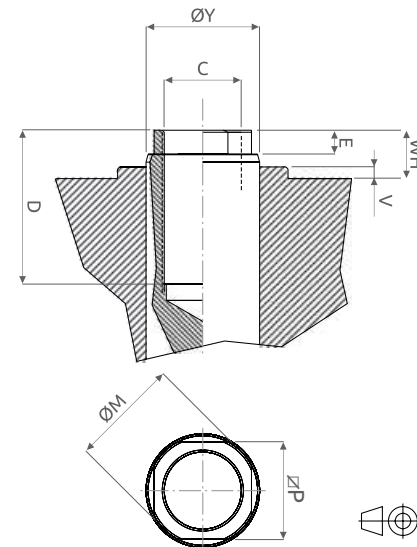

V450CM-YES

ØX	ØY				C		D	E	F	K		ØM	ØP	V	WH+F	WH
	A	H	L	M	METRIC	UNF				METRIC	UNF-UNEF					
	G	I	B													
50	28				M20×2,5	3/4-16	30	6	30	M20×1,5	3/4-16	27	24	3	42	12
		36								M27×2						
63	28				M20×2,5	3/4-16	30	7	30	M20×1,5	3/4-16	27	24	3	43,5	13,5
		36						8	40	M27×2						

NOTES: For dimensions where no tolerance is indicated, refer to DIN norm 7168-m.

ACHTUNG: Für Maße ohne Toleranzangaben gilt DIN 7168-m.

NOTE: Per le dimensioni senza indicazione di tolleranza, riferirsi alla norma DIN 7168-m.

NOTE: Pour les dimensions où la tolerance n'est pas indiquée, adressez-vous aux normes DIN 7168-m.

ØX

Bore Bohrung Alesaggio Alésage

ØY

Rod Kolbenstange Stelo Tige

Z

Stroke Hub Corsa Course

EN

CHOICE OF CYLINDER VERSION

DE

AUSWAHL DER ZYLINDERVERSION

IT

SCELTA DELLA VERSIONE DEL CILINDRO

FR

CHOIX DE LA VERSION DU VÉRIN

Z

050

+

MTA20X250

#

Base Cylinder Grundausführung Cilindro base Vérin base

EN

ROD END ACCESSORIES
for rod metric or UNF thread

DE

ZUBEHÖR KOLBENSTANGE
für Innengewinde metrisch oder UNF

IT

ACCESSORI STELO
per estremità filetto stelo metrico o UNF

FR

ACCESSOIRES DE LA TIGE
pour extrémité taraudée métrique ou UNF

#

None Ohne Nessuno Aucun

MTA

20X250

METRIC
(G, L)UNF-UNEF
(I, M)

ØX

ØY

#1

20X250

3/4-16

50

28

G

I

20X250

3/4-16

63

36

L

M

Metric Male Thread

Metrisches Aussengewinde

Filetto maschio metrico

Filetage male métrique

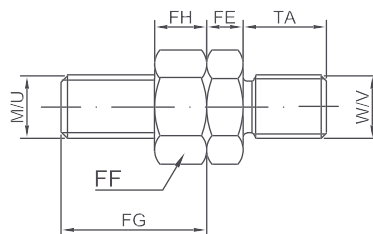
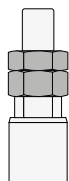

MFA

Floating Joint

Hammerkopf

Testa a martello

Tenon

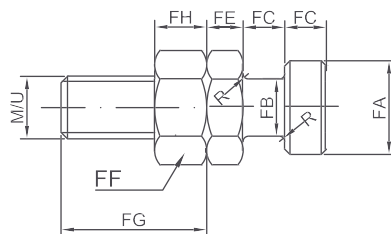
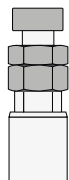

DFA

Floating Joint with Female

Hammerkopf mit Gegenstück

Testa a martello con femmina

Tenon avec femelle

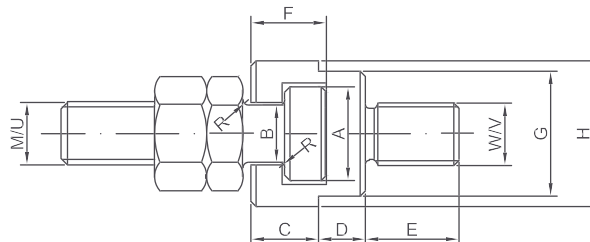
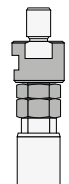

#1 : Compatible rod end code

Kode für passende Ausführung Kolbenstangenende

Cod. estremità stelo compatibile

Cod. extrémité tige compatible

V450CM-YES

		METRIC		UNF-UNEF		A	B	C	D	E	F	G	H	FA	FB	FC	FE	FF	FG		FH		TA	R
		M	W	U	V														M	U	M	U		
20X250	3/4-16	M20x2,5	M20x1,5	3/4-16	3/4-16	24	15	16	10	28	17,5	30	36	22	14	10	9	30	44	39	16	11	28	1,2

NOTES: For dimensions where no tolerance is indicated, refer to DIN norm 7168-m. **ACHTUNG:** Für Maße ohne Toleranzangaben gilt DIN 7168-m.

NOTE: Per le dimensioni senza indicazione di tolleranza, riferirsi alla norma DIN 7168-m.

NOTE: Pour les dimensions où la tolerance n'est pas indiquée, adressez-vous aux normes DIN 7168-m.

ØX Bore Bohrung Alesaggio Alésage

ØY Rod Kolbenstange Stelo Tige

Z Stroke Hub Corsa Course

- | | | | | |
|---|-------------------------|----------------------------|--------------------------------|-------------------------|
| 1 | Rod Cartridge | Führungsbuchse | Cartuccia stelo | Cartouche de la tige |
| 2 | Rod Seals Kit | Dichtungssset Kolbenstange | Kit guarnizioni stelo | Série joints de la tige |
| 3 | Rod Piston | Kolben-Stange | Stelo-pistone | Tige-piston |
| 4 | Piston Seals Kit | Dichtungssatz Kolben | Kit guarnizioni pistone | Série joints du piston |
| 5 | Body | Körper | Corpo | Corps |

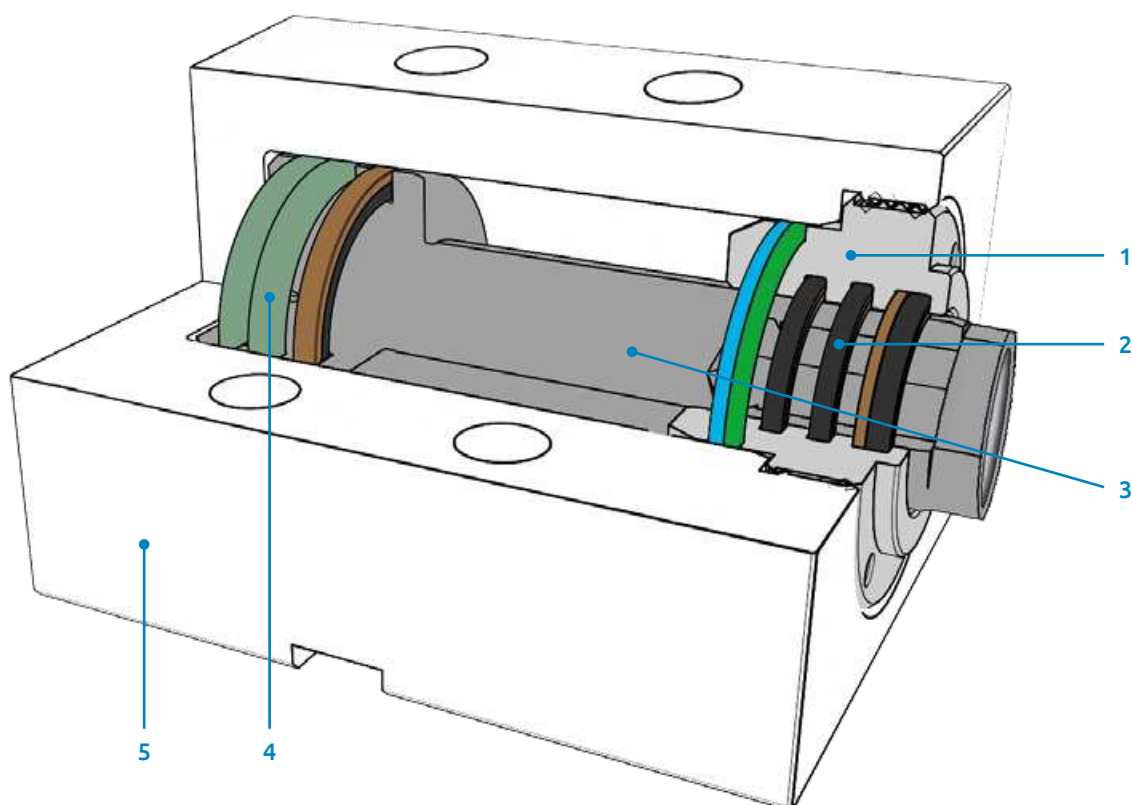

RM	...		Type Modell Modello Modèle	Cylinder Bore Zylinder Bohrung Alesaggio cilindro Alésage vérin	Article Code Artikelcode Codice articolo Code Article	Additional Set Code Zusätzlicher Kode Indicazione d'assieme Indication d'ensemble	Cylinder Stroke Hub Corsa cilindro Course du vérin		
RM	...	6010	A						Rod seals kit Dichtungssatz Kolbenstange Serie guarnizioni stelo Série joints de la tige 2
RM	...	6011	A						Bigger rod seals kit Dichtungs-Set für größere Kolbenstange Serie guarnizioni stelo maggiorato Série joints de la tige augmentée 2
RM	...	0310							Rod cartridge without seals Führungsbuchse ohne Dichtungen Cartuccia stelo senza guarnizioni Cartouche de la tige sans joints 1
RM	...	0311							Bigger rod cartridge without seals Gehäuse für größere Kolbenstange ohne Dichtungen Cartuccia stelo maggiorato senza guarnizioni Cartouche de la tige augmentée sans joints 1
RM	...	0310	A						Rod cartridge with seals Führungsbuchse mit Dichtungen Cartuccia stelo con guarnizioni Cartouche de la tige avec joints 1 + 2
RM	...	0311	A						Bigger rod cartridge with seals Gehäuse für größere Kolbenstange mit Dichtungen Cartuccia stelo maggiorato con guarnizioni Cartouche de la tige augmentée avec joints 1 + 2
RM	...	6020	A						Piston seal kit Dichtungssatz Kolben Serie guarnizioni pistone Série joints du piston 4
RM	...	1160	A						Piston-rod with female metric thread rod end, with seals - YES Kolben-Stange mit metrischem Innengewinde Kolbenstangenende, mit Dichtungen - YES Stelo-pistone con estremità filetto femmina metrico, con guarnizioni - YES Tige-piston avec extrémité taraudage métrique, avec joints - YES 3 + 4
RM	...	1170	A						Bigger piston-rod with female metric thread rod end, with seals - YES Größere Kolben-Stange-Einheit, Kolbenstangenende mit metrischem Innengewinde, mit Dichtungen - YES Stelo-pistone maggiorato con estremità filetto femmina metrico, con guarnizioni - YES Tige-piston augmentée avec extrémité taraudage métrique, avec joints - YES 3 + 4
RM	...	1161	A						Piston-rod with female UNF thread rod end, with seals - YES Kolben-Stange mit UNF Innengewinde Kolbenstangenende (U.S.A. Standard), mit Dichtungen - YES Stelo-pistone con estremità filetto femmina UNF (Standard USA), con guarnizioni - YES Tige-piston avec extrémité taraudage UNF (Standard USA), avec joints - YES 3 + 4
RM	...	1171	A						Bigger piston-rod with female UNF thread rod end, with seals - YES Größere Kolben-Stange-Einheit, Kolbenstangenende mit UNF Innengewinde, mit Dichtungen - YES Stelo-pistone maggiorato con estremità filetto femmina UNF (Standard USA), con guarnizioni - YES Tige-piston augmentée avec extrémité taraudage UNF (Standard USA), avec joints - YES 3 + 4
RM	...	1150	A						Piston-rod with male metric rod end, with seals - YES Kolben-Stange mit metrischem Aussengewinde Kolbenstangenende, mit Dichtungen - YES Stelo-pistone con estremità filetto maschio metrico, con guarnizioni - YES Tige-piston avec extrémité filetage métrique, avec joints - YES 3 + 4
RM	...	1151	A						Piston-rod with male UNF-UNEF rod end, with seal - YES Kolben-Stange mit UNF-UNEF Aussengewinde Kolbenstangenende, mit Dichtungen - YES Stelo-pistone con estremità filetto maschio UNF-UNEF (Standard USA), con guarnizioni - YES Tige-piston avec extrémité filetage UNF-UNEF, avec joints - YES 3 + 4
RM	...	1180	A						Bigger piston-rod with male metric thread rod end, with seals - YES Größere Kolbenstange mit metrischem Aussengewinde Kolbenstangenende, mit tungen - YES Stelo-pistone maggiorato con estremità filetto maschio metrico, con guarnizioni - YES Tige-piston augmentée avec extrémité filetage métrique, avec joints - YES 3 + 4
RM	...	1901E							Body for Clamping "D", O-ring ports, bottom, position "E" Körper für Befestigungsart "D", Ölschlüsse mit O-Ringen unterseite, Lage "E" Corpo fissaggio "D", orifizi tipo O-ring inferiori, posizione "E" Corps fixation "D", orifices intégrés dessous, position "E" 5
RM	...	1901I							Body for Clamping "D", O-ring ports, bottom, position "I" Körper für Befestigungsart "D", Ölschlüsse mit O-Ringen unterseite, Lage "I" Corpo fissaggio "D", orifizi tipo O-ring inferiori, posizione "I" Corps fixation "D", orifices intégrés dessous, position "I" 5
RM	...	6050							O-ring in FKM integrated oil delivery O-ring in FKM integrierten Ölschluß O-ring in FKM alimentazione integrata Joints toriques en Viton® alimentation de l'huile intégrée

