



ТОВ "Компанія "Парк" - офіційний представник в Україні!

+38 (093) 033-33-66
info@parkgroup.com.ua
www.parkgroup.com.ua



V220CC

V220CC

EN

Long Stroke Block Cylinder with or without Magnetic Switches Option

DE

Kompakte Hydraulikzylinder mit oder ohne Magnetische Endschalter

IT

Cilindri oleodinamici compatti a corsa lunga con o senza sensori magnetici di fine corsa

FR

Vérins blocs hydrauliques courses longues avec ou sans détecteurs magnétiques de fin de course

220
BAR



Ejection Plate Movement
Auswerferplattenbewegung
Movimentazione piastra di estrazione
Mouvement de la plaque d'éjection

 **VEGA**[®]
CYLINDERS

CAT. 2022/23.01.V220CC.01

EN

ORDER CODE

IT

CODICE ORDINE

DE

BESTELLCODE

FR

CODE COMMANDE

V220CC

Cylinder Model
Zylinder Modell
Modello cilindro
Modèle du vérin

CC

Bore
Bohrung
Alesaggio
Alésage

050

Clamping Style
Befestigungs Art
Fissaggio
Fixation

E

Oil Ports Type
Art der Anschlüsse
Tipo di orifici
Type d'orifice

G

Oil Ports Position
Lage der Leitungsanschlüsse
Posizione orifici
Position des orifices

H

PAGE SEITE PAGINA PAGE

C6

C8 > C11

C12 > C13

C12 > C13

ØX

032

B

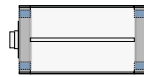

G

H

BSP Thread

BSP Gewinde

Filetto BSP

Filetage BSP

Left Side (Threaded)

Gewinde Links

Sinistra (filettati)

Gauche (fileté)

040

C

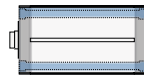

N

M

NPT Thread

NPT Gewinde

Filetto NPT

Filetage NPT

Right Side (Threaded)

Gewinde Rechts

Destra (filettati)

Droite (fileté)

050

E

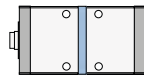

O

F

Manifold with O-Rings

Ölanschluß durch O-Ringe

Integrati con O-ring

Intégrés avec joint torique

Front Side (O-Rings)

Frontale Ölanschlüsse (durch O-Ringe)

Frontale (O-ring)

Avant (O-rings)

063

F

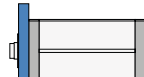

R

Rear Side (O-Rings)

Hintere Ölanschlüsse (durch O-Ringe)

Posteriore (O-ring)

Arrière (O-rings)

080

G

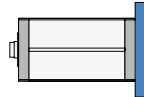

E

Bottom Side (O-Rings and Threaded)

Seitliche Ölanschlüsse (durch O-Ringe)

Lato inferiore (O-ring e filettati)

Dessous (O-rings)

100

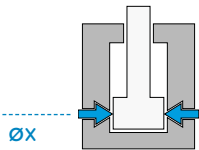
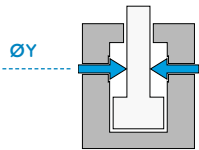

Rod end Type Kolbenstangen ausführung Estremità stelo Extrémité de la tige	Cylinder Version Zylinder-Version Versione cilindro Version du vérin	Stroke Hublänge Corsa Course	Quote, Only for "E" Clamping Maß, nur für Befestigungsart "E" Quota, solo per fissaggio "E" Côte, seulement pour fixation "E"	Rod Accessories Zubehör Kolbenstange Accessori stelo Accessoires de la tige	Magnetic Switches \ Switch Qty Magnetischer Sensor \ Anzahl der Sensoren Sensori magnetici \ Q.tà sensori DéTECTEURS magnétiques \ Q.té détecteurs
G	M	250	X099	MTA20X250	MSU4 \ 2

V220CC

C14 C15 C7 C9 C17 C15

G

Female Metric Thread
Metrisches Innengewinde
Filetto femmina metrico
Taroudage métrique

I

Female UNF Thread
UNF Innengewinde
Filetto femmina UNF
Taroudage UNF-UNEF

A

Male Metric Thread
Metrisches Aussengewinde
Filetto maschio metrico
Filetage métrique

H

Male UNF Thread
UNF Aussengewinde
Filetto maschio UNF
Filetage UNF-UNEF

F

Floating Joint
Hammerkopf
Testa a martello
Tenon

M

Preset for Magnetic Switches
Ausgerüstet für Magnetische Abfrage
Predisposto ai sensori magnetici
Prédisposition pour détecteurs magnétiques

W

Non-Magnetic, body without Switch Groove
Nicht magnetische, Zylinderkörper ohne Nut für Endschalter
Non magnetico, corpo senza cava sensori
Non magnétique, corps sans logement détecteurs

Z

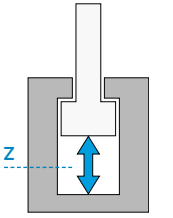

X

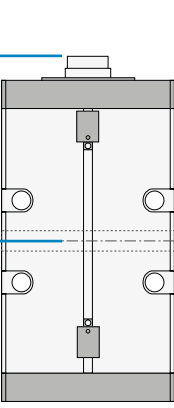

#

None
Keiner
Nessuno
Aucun



MTA

Male Thread
Aussengewinde
Filetto maschio
Filetage

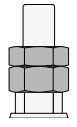

MFA

Floating Joint
Hammerkopf
Testa a martello
Tenon

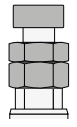

DFA

Floating Joint with Female
Hammerkopf mit Gegenstück
Testa a martello con femmina
Tenon male/femelle

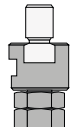

\

None
Ohne
Nessuno
Aucun

MSU4 \ 1
MSU4 \ 2

Magnetic Switches
Magnetische Endschalter
Sensori magnetici
DéTECTEURS magnétiques

Maximum Static Pressure Maximaler statischer Druck Pressione massima statica Pression statique maximale				
Magnetic Cylinder Magnetische Zylinder Cilindro magnetico Vérin magnétique		Non-Magnetic Cylinder Nicht magnetische Zylinder Cilindro non magnetico Vérin normal		
O-rings oil delivery Ölanschluß durch O-Ringe Alimentazione O-ring Alimentation O-rings		Threaded oil delivery Gewindebohrungen Orifizi filettati Orifices filetés		Threaded oil delivery Gewindebohrungen Orifizi filettati Orifices filetés
ØX	MPa - (bar) - PSI	MPa - (bar) - PSI	MPa - (bar) - PSI	MPa - (bar) - PSI
32	16(160) - 2320	22(220) - 3190	16(160) - 2320	22(220) - 3190
40	14 (140) - 2030	22(220) - 3190	14(140) - 2030	22(220) - 3190
50	14(140) - 2030	20(200) - 2900	14(140) - 2030	22(200) - 2900
63	12(120) - 1740	18(180) - 2610	12(120) - 1740	18(180) - 2610
80	12(120) - 1740	18(180) - 2610	12(120) - 1740	18(180) - 2610
100	12(120) - 1740	16(160) - 2320	12(120) - 1740	16(160) - 2320

ØX = Bore Bohrung Alesaggio Alésage

Maximum Nominal Delivery (Pushing) Nennwert Max. Durchflussmenge (beim Ausfahren) Portata max. nominale Débit nominal maximum (en poussée)		Maximum Piston Speed Maximale Geschwindigkeit des Kolbens Velocità massima pistone Vitesse maximum du vérin	Maximum Working Temperature Max. Betriebstemperatur Temperatura max. esercizio Température max. d'exercice	
Magnetic Cylinder Magnetische Zylinder Cilindro magnetico Vérin magnétique	Non-Magnetic Cylinder Nicht magnetische Zylinder Cilindro non magnetico Vérin normal		Magnetic Cylinder Magnetische Zylinder Cilindro magnetico Vérin magnétique	Non-Magnetic Cylinder Nicht magnetische Zylinder Cilindro non magnetico Vérin normal

ØX	l/min	l/min	m/s	80 °C 176 °F	100 °C 212 °F
32	4	4	0,1		
40	7	7	0,1		
50	10	10	0,1		
63	15	15	0,1		
80	30	30	0,1		
100	45	45	0,1		

EN

BORE SIZE AND STROKE

IT

ALESAGGIO E CORSA

DE

KOLBENDURCHMESSER UND HUBLÄNGE

FR

ALÉSAGES ET COURSES

CC

ØX

050

E

G

H

V220CC

Table for push and pull forces in daN (1 daN = 1 kgf)

Tabelle Druck- und Zugkraft in daN (1 daN=1 kgf)

Tabella forze in spinta e tiro in daN (1 daN = 1 kgf)

Tableau des forces de poussée et de traction en daN (1 daN=1 kgf)

ØX	ØY	8 MPa 80 bar 1160 PSI		10 MPa 100 bar 1450 PSI		12,5 MPa 125 bar 1812 PSI		16 MPa 160 bar 2320 PSI		20 MPa 200 bar 2900 PSI	
		Th	Tr	Th	Tr	Th	Tr	Th	Tr	Th	Tr
032	18	643	440	804	550	1005	688	1286	880	1608	1100
040	22	1005	701	1256	876	1570	1095	2010	1402	2512	1752
050	28	1570	1078	1963	1347	2453	1684	3140	2155	3925	2694
063	36	2493	1679	3116	2099	3895	2623	4985	3358	6231	4197
080	36	4019	3205	5024	4007	6280	5008	8038	6411	10048	8013
100	45	6280	5008	7850	6260	9813	7825	12560	10017	-	-

Th Thrust Druck Spinta Poussée

Tr Traction Zug Trazione Traction

ØX Bore Bohrung Alesaggio Alésage

ØY Rod Kolbenstange Stelo Tige

G	M	Z	X
		250	X099 + MTA20X250 \ MSU4 \ 2

Standard Strokes Table in mm

Standard Hublängen Tabelle in mm

Tabella corse standard in mm

Tableau des course standards en mm

Z	080	100	150	200	250	300
ØX						
32					#	#
40					#	#
50						#
63						#
80						
100						

ØX Bore Bohrung Alesaggio Alésage

Z Stroke Hub Corsa Course

Standard strokes Standard hublängen Corse standard Courses standard

Special strokes Sonderhublängen Corse speciali Courses spéciales

: Not available with longitudinal through holes (code "C") or with manifold oil delivery (code "OE", "OR" or "OF").

: Nicht verfügbar mit Befestigungsart "C" (längliche Durchgangsbohrungen) oder mit integriertem Anschluss über O-Ringe (Bezeichnung "OE", "OR" oder "OF").

: Non disponibile con fissaggio fori longitudinali passanti (codice "C") o con orifici integrati con O-ring (codici: "OE", "OR" o "OF").

: Non disponible avec trous passants longitudinaux (code "C") ou avec orifices intégrés avec O-rings (codes: "OE", "OR" ou "OF").

NOTES: For strokes shorter than 80 mm, we suggest our more compact and cheaper V250CE or V450CM.

BEMERKUNG: Für hublängen unter 80 mm sollten zylinder der reihe V250CE oder V450CM in Betracht gezogen werden, diese sind kompakter und günstiger.

NOTE: Per corse inferiori a 80 mm suggeriamo di scegliere i cilindri modello V250CE o V450CM che sono più compatti ed economici.

NOTE: Pour les courses inferieures a 80 mm: nous suggerons de choisir les vérins modele V250CE ou V450CM qui sont plus compacts et plus économique.

	Minimum Stroke Corsa minima	Min. Hub Course mini		Maximum Stroke Corsa massima	Maximum Hub Course max
	<p>With "E" code clamping + threaded oil ports</p> <p>Mit Befestigungsart "E" + Gewindeanschluss</p> <p>Con fissaggio codice "E" + orifici filettati</p> <p>Avec fixation code "E" + orifices filetés</p>	<p>With all other clampings and oil ports</p> <p>Mit allen anderen Befestigungs und Anschlussarten</p> <p>Con tutti gli altri fissaggi e orifici</p> <p>Avec toutes autres fixations et orifices</p>	<p>All clampings with "OF", "OR" and "OE" oil ports codes - with o-rings</p> <p>Für alle Befestigungsarten mit Anschlussbezeichnung "OF", "OR" und "OE" (mit O-Ringen)</p> <p>Per tutti i fissaggi con codice orifici "OF", "OR" e "OE" (con O-Ring)</p> <p>Pour toutes fixations avec type d'orifices "OF", "OR" et "OE" (avec o-rings)</p>	<p>Clamping code "C" with all oil ports types</p> <p>Für Befestigungsart "C" und alle Anschlussarten</p> <p>Per fissaggio "C" con tutti i tipi di orifici</p> <p>Pour fixation "C" avec tout type d'orifices</p>	<p>With all other clampings and oil ports</p> <p>Mit allen anderen Befestigungs und Anschlussarten</p> <p>Con tutti gli altri fissaggi e orifici</p> <p>Avec toutes autres fixations et orifices</p>
ØX	mm	mm		mm	mm
32	65	65	200	200	300
40	65	65	200	200	350
50	65	65	250	250	400
63	75	65	250	250	450
80	90	65	300	300	500
100	90	65	300	300	500

NOTE: Stroke tolerance: -0/+0.5 mm. Special strokes can be manufactures on request directly to our sales department

BEMERKUNG: Toleranz Hublänge: -0/+0,5 mm. Sonderhublängen sind auf Anfrage lieferbar. Weitere Auskunft gibt unser Verkauf.

NOTA: Tolleranza sulla corsa: -0/+0,5 mm. Corse speciali sono fornibili a richiesta. Contattare il nostro ufficio vendite.

NOTE: Tolérance sur courses: -0/+0,5 mm. Les courses spéciales peuvent être fournies. Contacter notre service technique.

EN

CHOICE OF CLAMPING STYLE

DE

AUSWAHL BEFESTIGUNGSART

IT

SCELTA DEL FISSAGGIO

FR

CHOIX DE LA FIXATION

CC

ØX

050

E

G

H

E

Lateral Through Holes with Keyway

Seitliche Durchgangsbohrungen mit Nut

Fori passanti laterali con chiavetta

Trous passant verticaux avec clavette

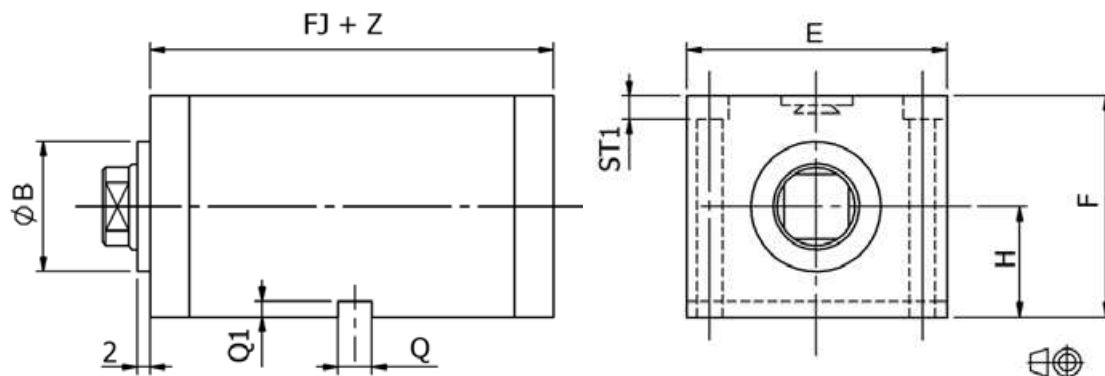
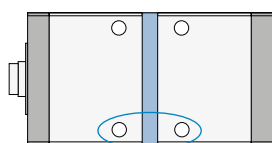

Tightening torque for cylinder-mold fixing screws
Anzugsmomente zur Verriegelung von Zylinder an der Form
Coppie di serraggio per viti di fissaggio cilindro-stampo
Couple de serrage pour les vis de fixation du vérin sur le moule

ØX	Nm
32	45
40	45
50	80
63	80
80	150
100	150

ØX	ØY	ØB ⁰ _{-0,1}	E	F	FJ+	H	Q H10	Q1	ST	ST1	XA	XB
32	18	32	75	65	86	32,5	10	5	10,5	11	50	58
40	22	40	85	75	98,5	37,5	12	5	10,5	11	60	65
50	28	50	100	87	106,5	43,5	15	5	12,5	13	70	75
63	36	63	120	102	108,5	52	15	5	12,5	13	70	90
80	36	70	150	125	121	65	20	5	17	17	80	110
100	45	90	170	145	130	75	20	5	17	17	80	130

NOTES: For dimensions where no tolerance is indicated, refer to DIN norm 7168-m.

ACHTUNG: Für Maße ohne Toleranzangaben gilt DIN 7168-m.

NOTE: Per le dimensioni senza indicazione di tolleranza, riferirsi alla norma DIN 7168-m.

NOTE: Pour les dimensions où la tolérance n'est pas indiquée, adressez-vous aux normes DIN 7168-m.

ØX

Bore Bohrung Alesaggio Alésage

ØY

Rod Kolbenstange Stelo Tige

Z

Stroke Hub Corsa Course

G	M	Z 250	X X099	+ MTA20X250 \ MSU4 \ 2
---	---	----------	-----------	------------------------

DIM "X" to be specified. See table.
 DIM ma X bitte festlegen. Siehe tabelle.
 DIM "X" da specificare. Vedi tabella.
 DIM "X" doit etre specifie. Voir tableau.

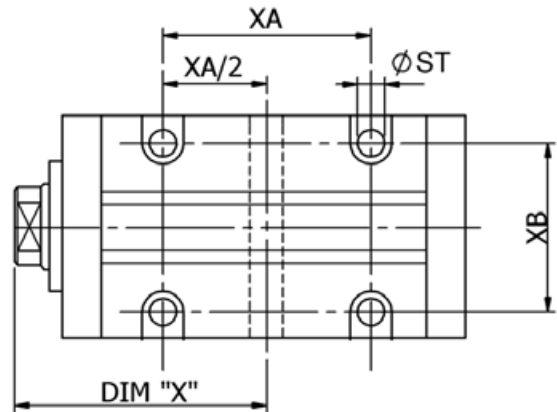

Dimensions "X" for threaded oil delivery version
 Ma "X" fr Ausfhrung mit Gewindeanschluss
 Quota "X" per versione con orifizi filettati
 Cte X pour version avec orifices filets

Dimensions "X" for manifold oil delivery version
 Ma "X" fr Ausfhrung mit Anschluss O-Ring
 Quota "X" per versione con orifizi con O-Ring
 Cte X pour version orifices avec O-Rings

ØX	MIN	MAX +		MIN	MAX +	
		Stroke	Hub / Corsa / Course		Stroke	Hub / Corsa / Course
32	078	028	028	068	038	038
40	087	037	037	073	043	043
50	099	034	034	086	046	046
63	107	032	032	091	051	051
80	121	031	031	108	043	043
100	131	041	041	118	053	053

NOTES: The keyway position as well as the fixing holes – which remain at same distance between each other as indicated with the quote XA - are customizable and must be indicated by the "X" quote. The table here above shows the minimum and maximum acceptable options.

ACHTUNG: Die Position der Befestigungsnut und die daraus resultierende Lage der Durchgangsbohrungen – die zueinander im gleichen abstand bleiben, wie Ma XA anzeigt - kann mit dem Ma "X" angegeben werden. Die tabelle ber zeigt den minimalen und maximalen wert.

NOTE: La posizione della chiavetta di fissaggio, con conseguente posizione dei fori di fissaggio – che restano comunque alla stessa distanza fra loro come indica la quota XA – è a scelta del cliente e va indicata con la quota "X". La tabella sopra ne indica quella minima e massima.

NOTE: La position de la clavette de fixation, se situe à gale distance des trous de fixation indique par la cte XA – à la prfrence du client celle ci doit tre note par la cte X. Le tableau ci-dessous montre le minimum et maximum acceptable.

EN

CHOICE OF CLAMPING STYLE

DE

AUSWAHL BEFESTIGUNGSART

IT

SCELTA DEL FISSAGGIO

FR

CHOIX DE LA FIXATION

CC

 $\varnothing X$

050

B

G

H

B

Front and Rear Threaded Holes

Gewindebohrungen vorne und hinten

Fori filettati anteriori e posteriori

Trous filetés avant et arrière

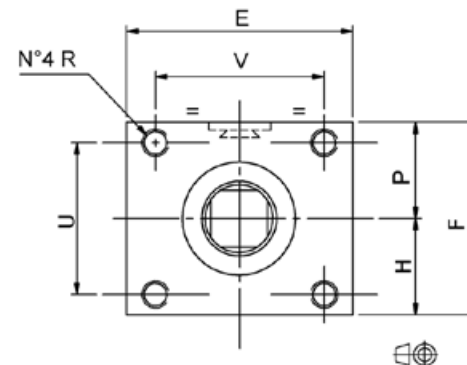
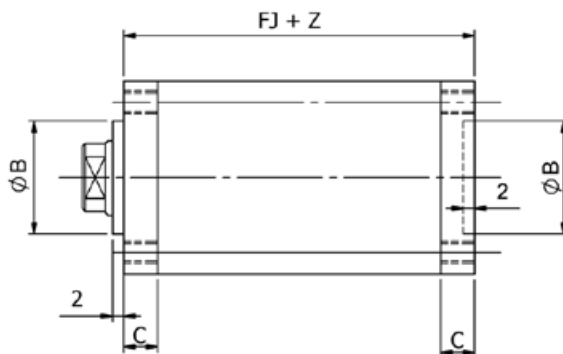
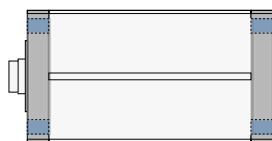

C

Longitudinal Through Holes

Längliche Durchgangsbohrungen

Fori passanti longitudinali

Trous passants longitudinaux

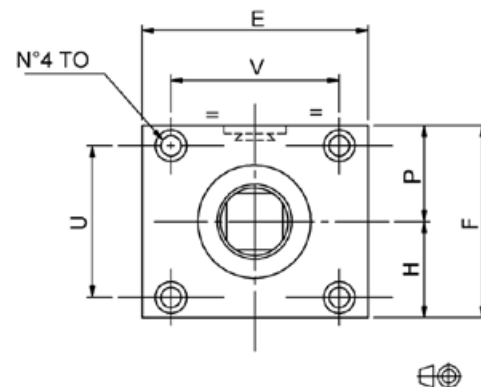
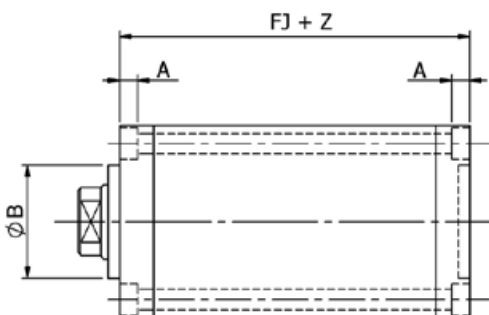
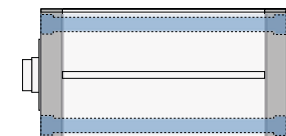

$\varnothing X$	$\varnothing Y$	A	$\varnothing B_{-0,1}^0$	C	E	F	FJ+	H	P	R	TO	U	V
32	18	9	32	15	75	65	86	32,5	32,5	M8×1,25	9	48	58
40	22	10,5	40	15	85	75	98,5	37,5	37,5	M10×1,5	11	55	65
50	28	13	50	19	100	87	106,5	43,5	43,5	M12×1,75	13,5	63	76
63	36	13	63	20	120	102	108,5	52	50	M12×1,75	13,5	78	96
80	36	17	70	27*	150	125	121	65	60	M16×2	17,5	90	120
100	45	17	90	27	170	145	130	75	70	M16×2	17,5	104	134

NOTES: For dimensions where no tolerance is indicated, refer to DIN norm 7168-m.

ACHTUNG: Für Maße ohne Toleranzangaben gilt DIN 7168-m.

NOTE: Per le dimensioni senza indicazione di tolleranza, riferirsi alla norma DIN 7168-m.

NOTE: Pour les dimensions où la tolérance n'est pas indiquée, adressez-vous aux normes DIN 7168-m.

* 26 for cap at rear

26 for cap at rear

26 per testata posteriore

26 for cap at rear

 $\varnothing X$

Bore Bohrung Alesaggio Alésage

 $\varnothing Y$

Rod Kolbenstange Stelo Tige

Z

Stroke Hub Corsa Course

G M Z 250 X X099 + MTA20X250 \ MSU4 \ 2

F

Front Flange
 Flansch vorne
 Flangia anteriore
 Bride avant

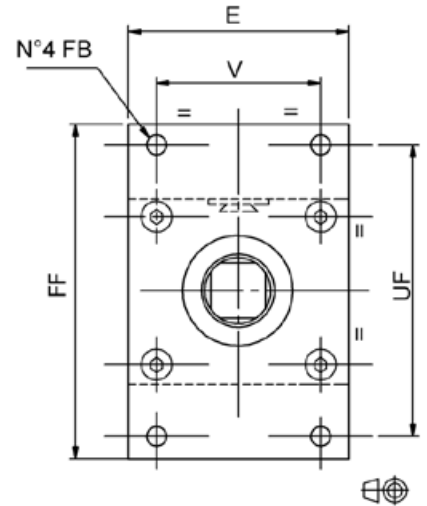
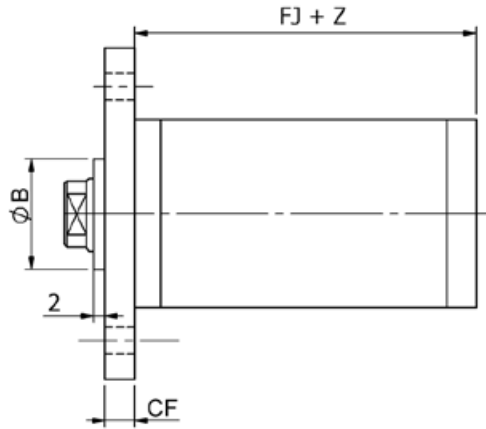
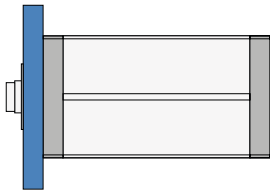

G

Rear Flange
 Flansch hinten
 Flangia posteriore
 Bride arrière

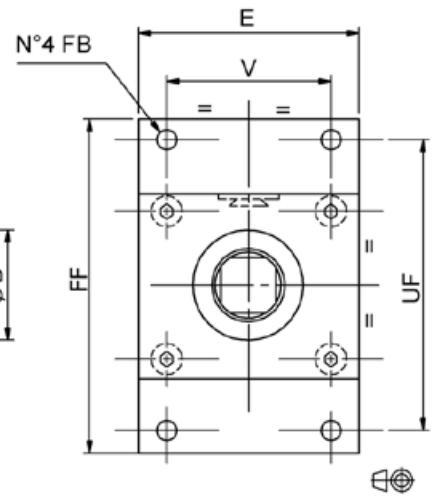
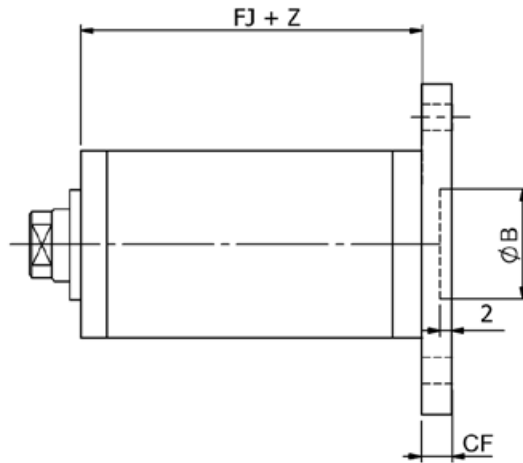
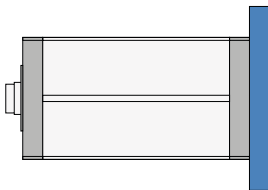

ØX	ØY	ØB ⁰ _{-0,1}	CF	E	FB	FF	FJ+	UF	V
32	18	32	15	75	11	120	86	94	58
40	22	40	15	85	11	130	98,5	104	65
50	28	50	20	100	13	150	106,5	120	76
63	36	63	20	120	13	165	108,5	136	96
80	36	70	27	150	17,5	210	121	170	120
100	45	90	27	170	17,5	230	130	190	134

NOTES: For dimensions where no tolerance is indicated, refer to DIN norm 7168-m.

ACHTUNG: Für Maße ohne Toleranzangaben gilt DIN 7168-m.

NOTE: Per le dimensioni senza indicazione di tolleranza, riferirsi alla norma DIN 7168-m.

NOTE: Pour les dimensions où la tolerance n'est pas indiquée, adressez-vous aux normes DIN 7168-m.

ØX Bore Bohrung Alesaggio Alésage ØY Rod Kolbenstange Stelo Tige Z Stroke Hub Corsa Course

CC

ØX

050

B

G

H

G

BSP Threaded Oil Delivery
Orifizi filettati BSP (Gas)Gewindebohrungen BSP (Gas)
Orifices filetés BSP (Gas)

N

NPT Threaded Oil Delivery
Orifizi filettati NPTGewindebohrungen NPT
Orifices filetés NPT

H

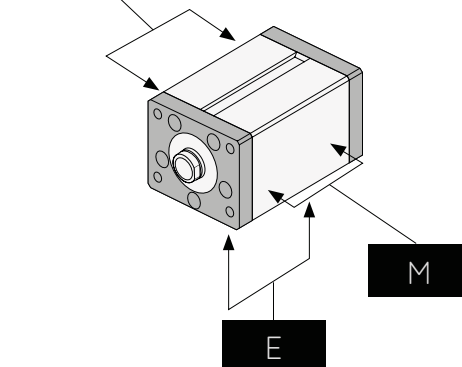
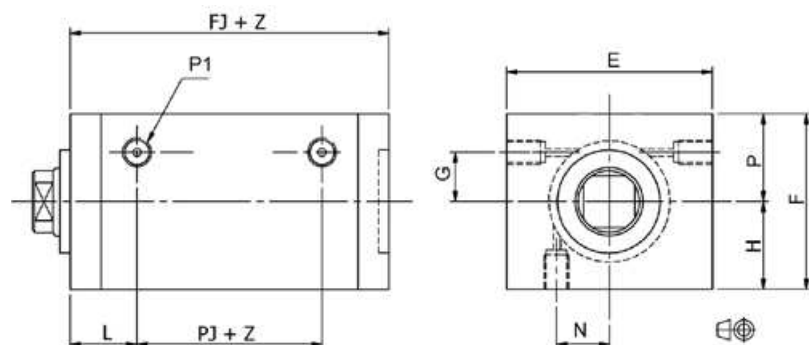
Left, Right or Bottom Side
Rechts, links oder unten
Lato sinistro, destro o sotto
Côté gauche ou droit ou dessous

O

Manifold Oil Delivery
Integrati con O-ringIntegrierte Ölanschluß durch O-Ringe
Intégrés avec O-rings

F

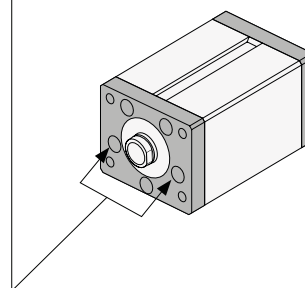
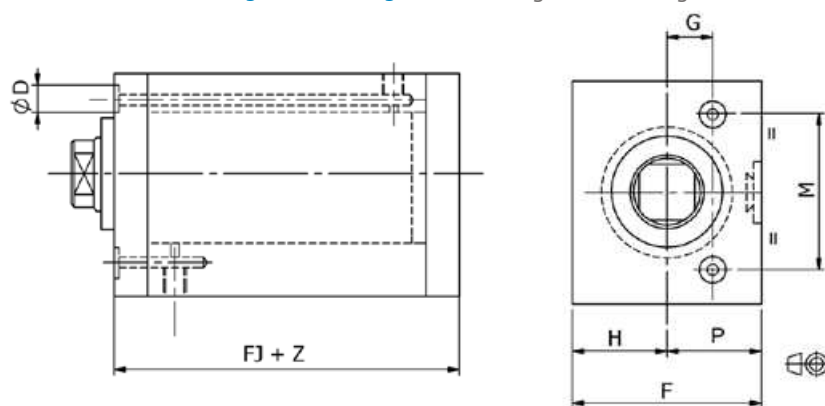
Front Side (Only for Clamping B, C and G)
Vorne (Nur für Befestigungsart B, C und G)
Lato frontale (solo per fissaggio B, C e G)
Avant (seulement pour fixations B, C et G)

NOTES FOR MANIFOLD OIL DELIVERY: Max. bore of oil delivery hole in the mold: 4.5 mm for cylinder bore 32 to 50; 6 mm for other cylinder bores.
Max. eccentricity 0.5 mm. FKM O-Rings are included.

ACHTUNG BEI ANSCHLUSS ÜBER O-RINGE: Max. Bohrungsdurchmesser der Ölversorgung: 4,5 mm für Zylinder mit Kolbendurchmesser von 32 bis 50; 6 mm für alle anderen. Unmittigkeit max. 0,5 mm. O-Ringe aus FKM sind im Lieferumfang enthalten.

NOTE PER ORIFIZI CON O-RING: Diametro max. del foro di alimentazione da eseguire nello stampo: 4,5 mm per alesaggio cilindro da 32 a 50; 6 mm per gli altri.
Eccentricità max. 0,5 mm. Gli O-ring in FKM sono inclusi nella fornitura.

NOTE POUR ORIFICES AVEC O-RINGS: Diamètre max. des trous d'alimentation dans le moule: 4,5 mm. Pour alésages de 32 à 50 ; 6 mm pour les autres alésages.
Excentricité max. 0,5 mm. Les O-rings en FKM sont inclus dans la fourniture.

ØX	ØY	ØD	E	F	FJ+	G	H	L	M	N	P	P1		PJ+
												NPT	BSP	
32	18	10	75	65	86	8	32,5	24	51	14	32,5	1/4"	1/4"	38
40	22	10	85	75	98,5	10	37,5	27	57	17	37,5	1/4"	1/4"	44,5
50	28	10	100	87	106,5	10	43,5	34	68	20	43,5	1/4"	1/4"	38,5
63	36	13	120	102	108,5	10	52	35	90	22	50	1/4"	1/4"	38,5
80	36	13	150	125	121	15	65	44	105	25	60	3/8"	3/8"	34
100	45	13	170	145	130	20	75	47	124	30	70	3/8"	3/8"	36

NOTES: For dimensions where no tolerance is indicated, refer to DIN norm 7168-m.

ACHTUNG: Für Maße ohne Toleranzangaben gilt DIN 7168-m.

NOTE: Per le dimensioni senza indicazione di tolleranza, riferirsi alla norma DIN 7168-m.

NOTE: Pour les dimensions où la tolérance n'est pas indiquée, adressez-vous aux normes DIN 7168-m.

G	M	Z	X
		250	X099 + MTA20X250 \ MSU4 \ 2



Manifold Oil Delivery
Integrati con O-ring

Integrierte Ölanschluß durch O-Ringe
Intégrés avec O-rings

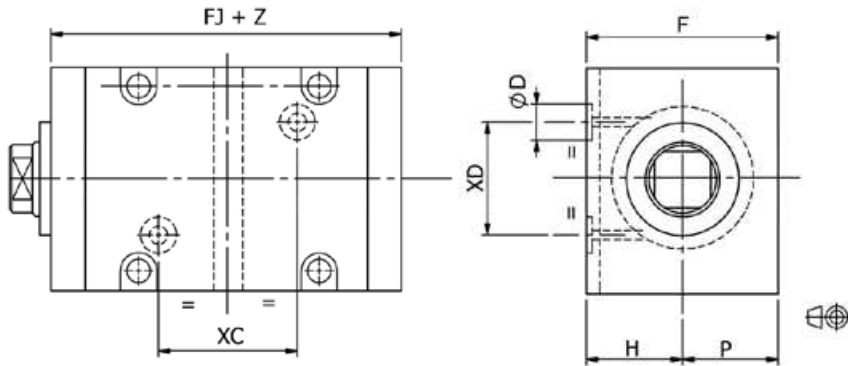

Bottom Side, Only for Clamping E
(Tightening torque - page C8)

Kurze Seite, Nur für Befestigung-
sart E (Anzugsmoment - seite C8)

Lato inferiore, solo per fissaggio
E (Coppia serraggio - pagina C8)

Dessous, seulement pour fixation
E (Couple de serrage - page C8)

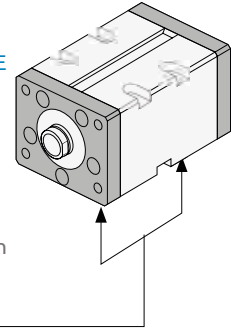

Manifold Oil Delivery
Integrati con O-ring

Integrierte Ölanschluß durch O-Ringe
Intégrés avec O-rings

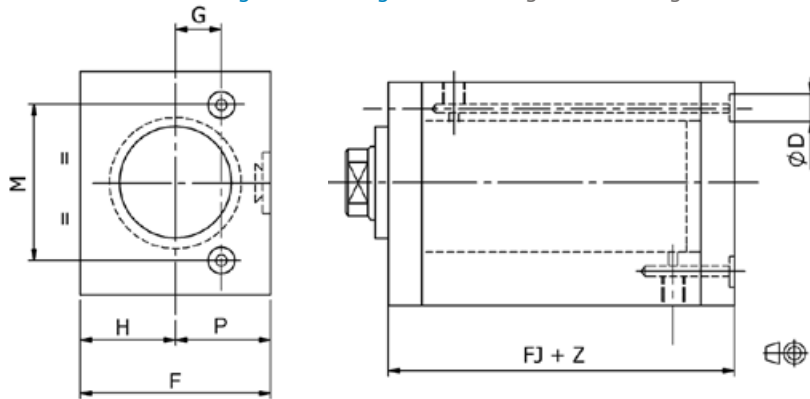

Rear Side, Only for Clamping B, C and F

Hinten, Nur für Befestigungsart B, C und F

Lato posteriore, solo per fissaggio B, C e F

Côté Arrière, seulement pour fixations B, C et F

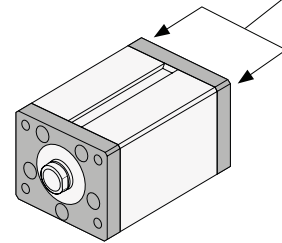

NOTES FOR MANIFOLD OIL DELIVERY: Max. bore of oil delivery hole in the mold: 4.5 mm for cylinder bore 32 to 50; 6 mm for other cylinder bores.
Max. eccentricity 0.5 mm. FKM O-Rings are included.

ACHTUNG BEI ANSCHLUSS ÜBER O-RINGE: Max. Bohrungsdurchmesser der Ölversorgung: 4,5 mm für Zylinder mit Kolbendurchmesser von 32 bis 50; 6 mm für alle anderen. Unmittigkeit max. 0,5 mm. O-Ringe aus FKM sind im Lieferumfang enthalten.

NOTE PER ORIFIZI CON O-RING: Diametro max. del foro di alimentazione da eseguire nello stampo: 4,5 mm per alesaggio cilindro da 32 a 50; 6 mm per gli altri.
Eccentricità max. 0,5 mm. Gli O-ring in FKM sono inclusi nella fornitura.

NOTE POUR ORIFICES AVEC O-RINGS: Diamètre max. des trous d'alimentation dans le moule: 4,5 mm. Pour alésages de 32 à 50 ; 6 mm pour les autres alésages.
Excentricité max. 0,5 mm. Les O-rings en FKM sont inclus dans la fourniture.

ØX	ØY	ØD	F	FJ+	G	H	M	P	XC	XD
32	18	10	65	86	8	32,5	51	32,5	30	36
40	22	10	75	98,5	10	37,5	57	37,5	35	40
50	28	10	87	106,5	10	43,5	68	43,5	40	46
63	36	13	102	108,5	10	52	90	50	40	50
80	36	13	125	121	15	65	105	60	45	70
100	45	13	145	130	20	75	124	70	45	80

NOTES: For dimensions where no tolerance is indicated, refer to DIN norm 7168-m.

ACHTUNG: Für Maße ohne Toleranzangaben gilt DIN 7168-m.

NOTE: Per le dimensioni senza indicazione di tolleranza, riferirsi alla norma DIN 7168-m.

NOTE: Pour les dimensions où la tolérance n'est pas indiquée, adressez-vous aux normes DIN 7168-m.

ØX	Bore	Bohrung	Alesaggio	Alésage	ØY	Rod	Kolbenstange	Stelo	Tige	Z	Stroke	Hub	Corsa	Course
----	------	---------	-----------	---------	----	-----	--------------	-------	------	---	--------	-----	-------	--------

EN

CHOICE OF ROD END STYLE

DE

AUSWAHL KOLBENSTANGENENDE

IT

SCELTA DELL' ESTREMITÀ DELLO STELO

FR

CHOIX DE L'EXTRÉMITÉ DE LA TIGE

CC

ØX

050

B

G

H

V220CC

Rod End Style Description Beschreibung des kolbenstangenendes Descrizione tipo di estremità Description du type d'extrémité de la tige

G

Metric Female Thread

Metrisches Innen Gewinde

Filetto femmina metrico

Taroudage métrique

A

Metric Male Thread

Metrisches Aussen Gewinde

Filetto maschio metrico

Filetage métrique

F

Floating Joint

Hammerkopf

Testa a martello

Tenon

I

UNF-UNEF Female Thread (U.S.A. Standard)

UNF-UNEF Innengewinde (U.S.A. Standard)

Filetto femmina UNF-UNEF (Standard U.S.A.)

Taroudage UNF-UNEF (Standard U.S.A.)

H

UNF-UNEF Male Thread (U.S.A. Standard)

UNF-UNEF Aussengewinde (U.S.A. Standard)

Filetto maschio UNF-UNEF (Standard U.S.A.)

Filetage UNF-UNEF (Standard U.S.A.)

A / H

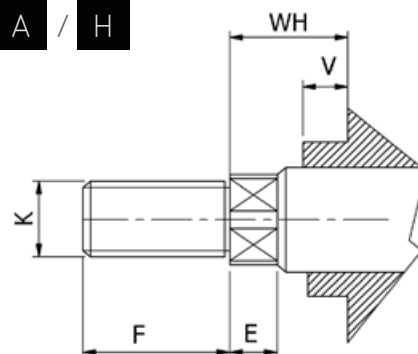

F

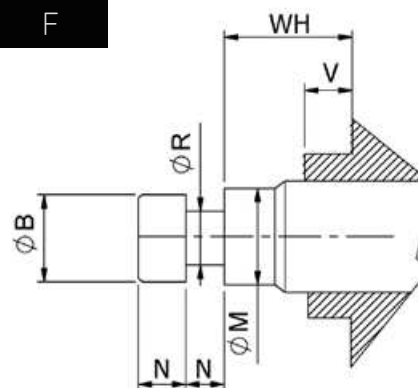

G / I

I

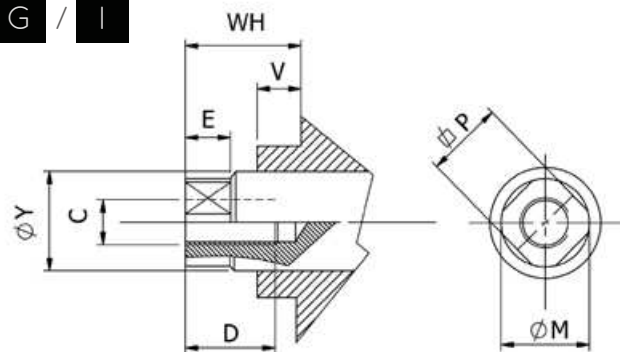

ØX	ØY	ØB	C		D	E	F	ØM	N	K		ØP	ØR	V	WH
			METRIC	UNF-UNEF						METRIC	UNF-UNEF				
32	18	16	M10×1,5	3/8-24	20	6	18	17	7	M14×1,5	9/16-18	15	10	2	10
40	22	18	M12×1,75	1/2-20	20	8	22	21	8	M16×1,5	5/8-18	18	11	2	11,5
50	28	22	M20×2,5	3/4-16	30	8	28	27	10	M20×1,5	3/4-16	24	14	2	13
63	36	28	M27×3	1/12	40	11	36	35	12.5	M27×2	1-12	32	18	2	15
80	36	28	M27×3	1/12	40	11	36	35	12.5	M27×2	1-12	32	18	2	15
100	45	35	M33×3,5	1-1/4-12	50	12	45	44	16	M33×2	1-1/4-12	40	22	2	21

ØX

Bore

Bohrung

Alesaggio

Alésage

ØY

Rod

Kolbenstange

Stelo

Tige

Z

Stroke

Hub

Corsa

Course

EN

CHOICE OF CYLINDER VERSION

DE

AUSWAHL DER ZYLINDERVERSION

IT

SCELTA DELLA VERSIONE DEL CILINDRO

FR

CHOIX DE LA VERSION DU VÉRIN

G

M

Z

250

X

X099

+ MTA20X250 \

MSU4 \ 2

V220CC

Description Beschreibung Descrizione Description

M

Cylinder with preset for magnetic switches (switches not included)

Zylinder zur magnetischen Endlagenabfrage ausgerüstet (jedoch ohne Sensoren)

Cilindro con predisposizione per sensori magnetici (sensori non inclusi)

Vérin avec predisposition pour montage des détecteurs (détecteurs non inclus)

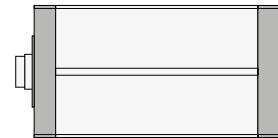

W

Non-Magnetic Cylinder, without switch groove

Nicht magnetische Zylinder, ohne Nut für Endschalter

Cilindro non magnetico, senza cava sensori

Vérin non magnétique, sans logement détecteurs



EN

MAGNETIC SWITCHES

only for "M" version (usually two for cylinder)

DE

MAGNETSCHALTER

nur für Ausführung "M" (normalerweise zwei pro Zylinder)

IT

SENSORI MAGNETICI

solo per versione "M" (solitamente due per cilindro)

FR

DÉTECTEURS MAGNÉTIQUES DE FIN DE COURSE

uniquement pour version "M" (habituellement deux par vérin)

\

MSU4 \ 1

MSU4 \ 2

None

Ohne

Nessuno

Aucun

Magnetic Switches

Magnetische Endschalter

Sensori magnetici

Détecteurs magnétiques

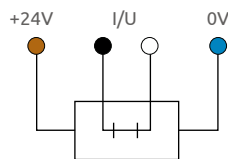
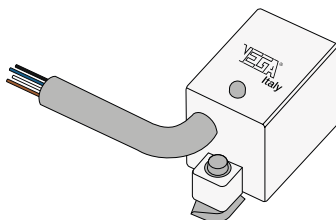
NOTE: The minimum cylinder stroke for two switches is 65 mm**ACHTUNG:** Der minimale Hub für Zylinder mit zwei Endschalter ist 65 mm**NOTA:** La corsa minima del cilindro per due sensori è di 65 mm**NOTE:** La course minimum du vérin pour deux détecteurs est de mm 65

Wire Color Anschlussfarben Colore conduttori Couleurs des conducteurs

● Brown Braun Marrone Brun = +24V DC

● Blue Blau Blu Bleu = 0V DC

● Black Schwarz Nero Noir = In/Out Contact Kontak Contatto Contact

○ White Weiß Bianco Blanc = In/Out Contact Kontak Contatto Contact

I/U = In/Out

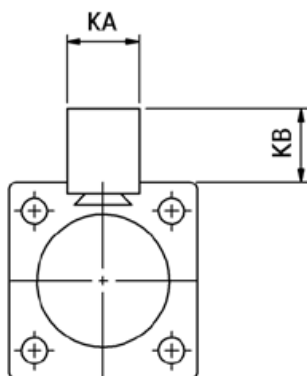

ØX	KA	KB
32		20
40		20
50		20
63	22	25,5
80		25,5
100		25,5

ØX Bore Bohrung Alesaggio Alésage

NOTES: For 2-wire Reed Switches, contact our Sales or Technical Department.**ACHTUNG:** Für 2-Leiter-Reed Mikroendschalter, wenden Sie sich an unseren Verkauf oder unsere Technische Abteilung.**NOTE:** Per eventuali richieste di sensori magnetici Reed a 2 fili, contattare il nostro ufficio vendite o tecnico.**NOTE:** Pour les détecteurs magnétiques Reed à 2 fils, contactez notre service commercial ou technique.

EN

ROD END ACCESSORIES
 for rod metric or UNF thread

DE

ZUBEHÖR KOLBENSTANGE
 für innengewinde metrisch oder UNF

IT

ACCESSORI STELO
 per estremità filetto stelo metrico o UNF

FR

ACCESSOIRES DE LA TIGE
 pour extrémité taraudée métrique ou UNF

ØX

CC

050

B

G

H

#

None Ohne Nessuno Aucun

MTA

10X150

METRIC (G) UNF-UNEF (I) ØX ØY #1

Metric Male Thread

Metrisches Aussengewinde

Filetto maschio metrico

Filetage male métrique

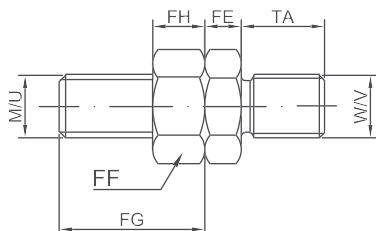
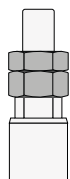

METRIC (G)	UNF-UNEF (I)	ØX	ØY	#1
10X150	3/8-24	32	18	G I
12X175	1/2-20	40	22	G I
20X250	3/4-16	50	28	G I
27X300	1-12	63	36	G I
27X300	1-12	80	36	G I
33X350	1-1/4-12	100	45	G I

MFA

Floating Joint

Hammerkopf

Testa a martello

Tenon

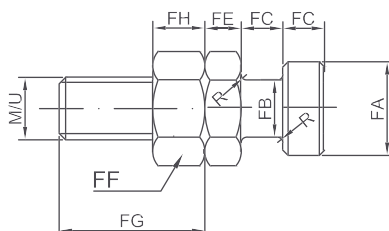
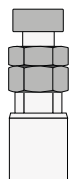
#1 : Compatible rod end code

Kode für passende Ausführung Kolbenstangenende

Cod. estremità stelo compatibile

Cod. extrémité tige compatible

DFA

Floating Joint with Female

Hammerkopf mit Gegenstück

Testa a martello con femmina

Tenon avec femelle

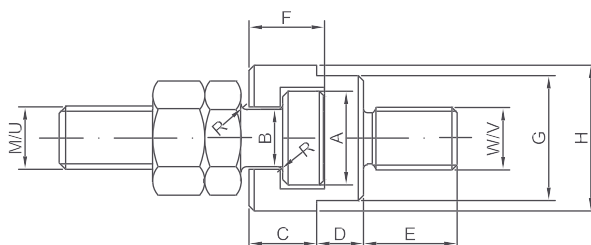
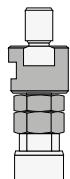
NOTES: For Rod Accessories with high performance steel, see VR/BAG, page V5.

ACHTUNG: Zubehör für Kolbenstange mit hochleistungsstahl, siehe VR/BAG, Seite V5.

NOTE: Per accessori stelo con acciaio ad alte prestazioni, vedi VR/BAG, pagina V5.

NOTE: Pour les accessoires de tige acier haute performance, voir VR/BAG, page V5.

G M Z 250 X X099 + MTA20X250 \ MSU4 \ 2

		METRIC		UNF-UNEF		A	B	C	D	E	F	G	H	FA	FB	FC	FE	FF	FG		FH		TA	R
		M	W	U	V														M	U	M	U		
10X150	3/8-24	M10×1,5	M10×1,25	3/8-24	3/8-24	17,5	11	11	8	16	12,5	21	25	16	10	7	6	17	24	24	8	6	14	1
12X175	1/2-20	M12×1,75	M12×1,25	1/2-20	1/2-20	19,5	12	13	9	18	14,5	24	28	18	11	8	7	19	28	28	10	8	16	1,2
20X250	3/4-16	M20×2,5	M20×1,5	3/4-16	3/4-16	24	15	16	10	28	17,5	30	36	22	14	10	9	30	44	39	16	11	28	1,2
27X300	1-12	M27×3	M27×2	1-12	1-12	30	19	20	12	40	23	36	44	28	18	12,5	12	36	57	52	22	14	36	1,5
33X350	1-1/4-12	M33×3,5	M33×2	1-1/4-12	1-5/16-18	39	23	23	14	50	27,5	46	55	35	22	16	14	46	64	64	14	27	45	2

NOTES: For dimensions where no tolerance is indicated, refer to DIN norm 7168-m.

ACHTUNG: Für Maße ohne Toleranzangaben gilt DIN 7168-m.

NOTE: Per le dimensioni senza indicazione di tolleranza, riferirsi alla norma DIN 7168-m.

NOTE: Pour les dimensions où la tolerance n'est pas indiquée, adressez-vous aux normes DIN 7168-m.

ØX Bore Bohrung Alesaggio Alésage

ØY Rod Kolbenstange Stelo Tige

Z Stroke Hub Corsa Course

1	Magnetic switch	Magnetische Endschalter	Sensore magnetico	Détecteur magnétique
2	Piston seals kit	Dichtungssatz Kolben	Kit guarnizioni pistone	Série joints du piston
3	Magnet	Magnet	Magnete	Aimant
4	Piston	Kolben	Pistone	Piston
5	Body	Körper	Corpo	Corps
6	Rod	Kolbenstange	Stelo	Tige
7	Rod seals kit	Kolbenstangendichtungsset	Kit guarnizioni stelo	Série joints de la tige

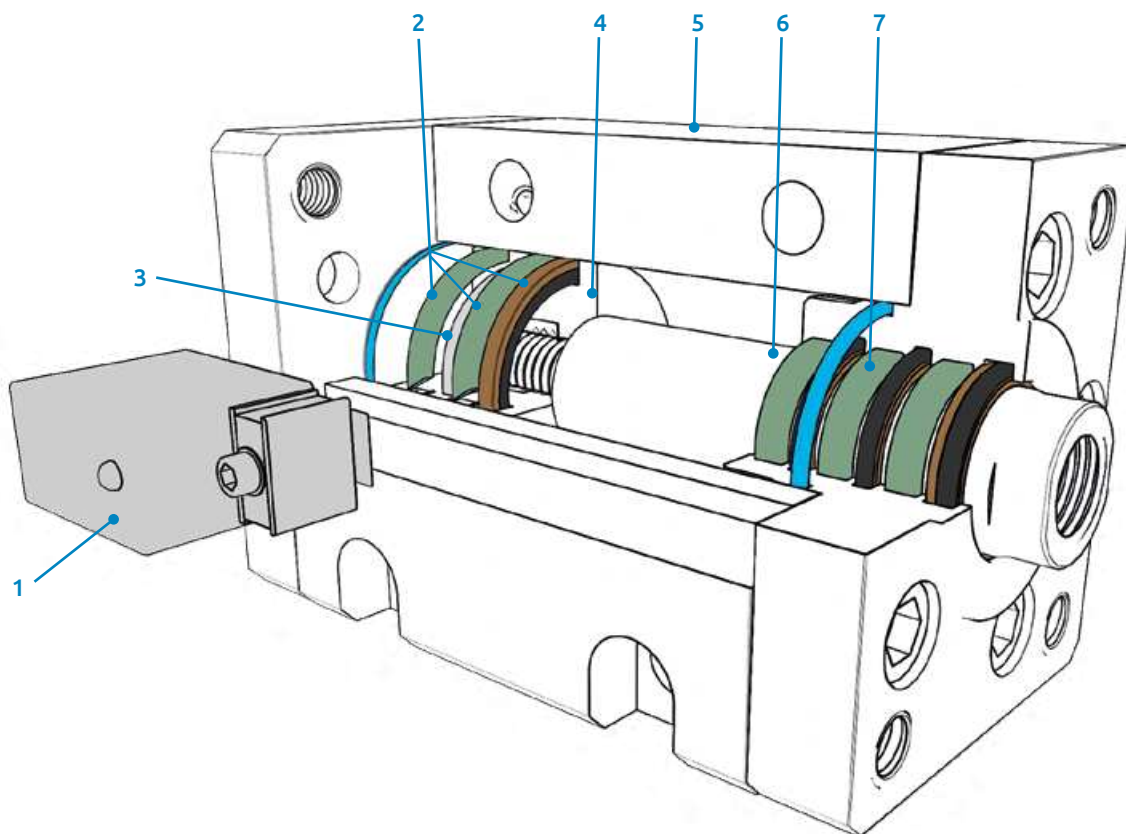

Type	Modell	Modello	Modèle	Cylinder Bore	Article Code	Ports Position	Additional Set Code	Cylinder Stroke	"X" Quote					
RC	...	6010	A	032	6010		A							
				Zylinder Bohrung	Artikelcode	Lage der Leitungsanschlüsse	Zusätzlicher Code	Hub	Quote "X"					
				Alésaggio cilindro	Codice articolo	Posizione orifici	Indicazione d'assieme	Corsa cilindro	Quota "X"					
				Alésage du vérin	Code article	Position des orifices	Indication d'ensemble	Course du vérin	Côte "X"					
RC	...	6010	A							Rod seals kit	Dichtungssatz Kolbenstange	Serie guarnizioni stelo	Série joints de la tige	7
RC	...	6020	A							Piston seals kit	Dichtungssatz Kolben	Serie guarnizioni pistone	Série joints du piston	2
RC	...	6050								Magnet	Magnet	Magnete	Aimant	3
RC	...	6030								Manifold oil delivery FKM O-rings	O-Ring für integrierte Ölschlüsse	O-ring per alimentazione olio integrata	Joints toriques pour alimentation d'huile intégrée	-
RC	...	1510	A							Magnetic piston with seals	Magnetischer Kolben mit Dichtungen	Pistone magnetico con guarnizioni	Piston pour vérin magnétique avec joints	2 + 3 + 4
RC	...	1520	A							Non-magnetic piston with seals	Kolben mit Dichtungen für nicht magnetische Ausführung	Pistone non magnetico con guarnizioni	Piston non magnétique avec joints	2 + 4
RC	...	1910	.							Body for Clamping "B", BSP threaded ports	Körper für Befestigungsart "B", Gewindebohrung BSP	Corpo fissaggio "B" orifici filettati BSP	Corps avec fixation "B", orifices filetés BSP	5
RC	...	1911	.							Body for Clamping "B", NPT threaded ports	Körper für Befestigungsart "B", Gewindebohrung NPT	Corpo fissaggio "B" orifici filettati NPT	Corps avec fixation "B", orifices filetés NPT	
RC	...	1912	.							Body for Clamping "B", manifold ports	Körper für Befestigungsart "B", integrierte Ölschlüsse mit O-Ringen	Corpo fissaggio "B" orifici integrati con O-ring	Corps fixation "B", orifices intégrés avec joints toriques	
RC	...	1920	.							Body for Clamping "C", BSP threaded ports	Körper für Befestigungsart "C", Gewindebohrung BSP	Corpo fissaggio "C" orifici filettati BSP	Corps avec fixation "C", orifices filetés BSP	
RC	...	1921	.							Body for Clamping "C", NPT threaded ports	Körper für Befestigungsart "C", Gewindebohrung NPT	Corpo fissaggio "C" orifici filettati NPT	Corps avec fixation "C", orifices filetés NPT	
RC	...	1922	.							Body for Clamping "C", manifold ports	Körper für Befestigungsart "C", integrierte Ölschlüsse mit O-Ringen	Corpo fissaggio "C" orifici integrati con O-ring	Corps fixation "C", orifices intégrés avec joints toriques	

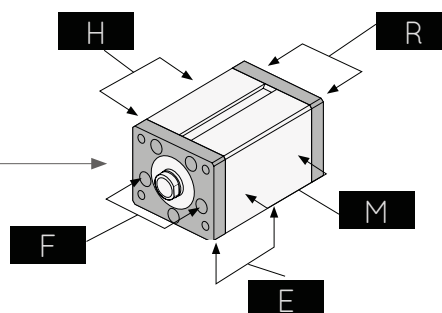

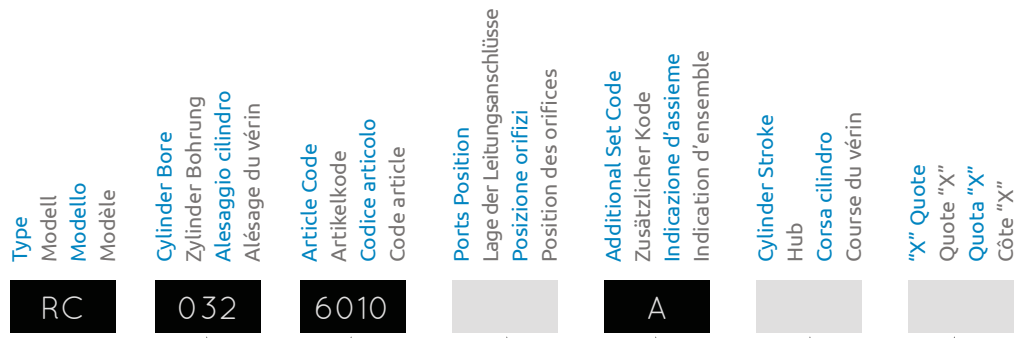

RC	...	1940	Body for Clamping "E", BSP threaded ports Körper für Befestigungsart "E", Gewindebohrung BSP Corpo fissaggio "E" orifici filettati BSP Corps avec fixation "E", orifices filetés BSP
RC	...	1941	Body for Clamping "E", NPT threaded ports Körper für Befestigungsart "E", Gewindebohrung NPT Corpo fissaggio "E" orifici filettati NPT Corps avec fixation "E", orifices filetés NPT
RC	...	1930	Body for Clamping "E", manifold ports Körper für Befestigungsart "E", integrierte Ölschlüsse mit O-Ringen Corpo fissaggio "E" orifici integrati con O-ring Corps fixation "E", orifices intégrés avec joints toriques
RC	...	1960	Body for clamping "B", BSP threaded ports, version "W" Körper für Befestigungsart "B", Gewindebohrung BSP, Ausführung "W" Corpo fissaggio "B", orifici filettati BSP, versione "W" Corps avec fixation "B", orifices filetés BSP, version "W"
RC	...	1961	Body for clamping "B", NPT threaded ports, version "W" Körper für Befestigungsart "B", Gewindebohrung NPT, Ausführung "W" Corpo fissaggio "B", orifici filettati NPT, versione "W" Corps avec fixation "B", orifices filetés NPT, version "W"
RC	...	1962	Body for clamping "B", manifold ports, version "W" Körper für Befestigungsart "B", integrierte Ölschlüsse mit O-Ringen, Ausführung "W" Corpo fissaggio "B", orifici integrati con O-ring, versione "W" Corps fixation "B", orifices intégrés avec joints toriques, version "W"
RC	...	1970	Body for clamping "C", BSP threaded ports, version "W" Körper für Befestigungsart "C", Gewindebohrung BSP, Ausführung "W" Corpo fissaggio "C", orifici filettati BSP, versione "W" Corps avec fixation "C", orifices filetés BSP, version "W"
RC	...	1971	Body for clamping "C", NPT threaded ports, version "W" Körper für Befestigungsart "C", Gewindebohrung NPT, Ausführung "W" Corpo fissaggio "C", orifici filettati NPT, versione "W" Corps avec fixation "C", orifices filetés NPT, version "W"
RC	...	1972	Body for clamping "C", manifold ports, version "W" Körper für Befestigungsart "C", integrierte Ölschlüsse mit O-Ringen, Ausführung "W" Corpo fissaggio "C", orifici integrati con O-ring, versione "W" Corps fixation "C", orifices intégrés avec joints toriques, version "W"
RC	...	1990	Body for clamping "E", BSP threaded ports, version "W" Körper für Befestigungsart "E", Gewindebohrung BSP, Ausführung "W" Corpo fissaggio "E", orifici filettati BSP, versione "W" Corps avec fixation "E", orifices filetés BSP, version "W"
RC	...	1991	Body for clamping "E", NPT threaded ports, version "W" Körper für Befestigungsart "E", Gewindebohrung NPT, Ausführung "W" Corpo fissaggio "E", orifici filettati NPT, versione "W" Corps avec fixation "E", orifices filetés NPT, version "W"
RC	...	1980	Body for clamping "E", manifold ports, version "W" Körper für Befestigungsart « E », integrierte Ölschlüsse mit O-Ringen, Ausführung "W" Corpo fissaggio "E", orifici integrati con O-ring, versione "W" Corps fixation "E", orifices intégrés avec joints toriques, version "W"

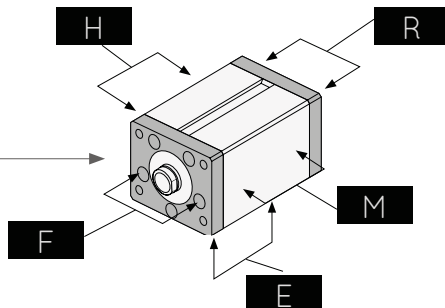

Type Modell Modello Modèle	Cylinder Bore Zylinder Bohrung Alésaggio cilindro Alésage du vérin	Article Code Artikelcode Codice articolo Code article	Additional Set Code Zusätzlicher Kode Indicazione d'assieme Indication d'ensemble	Cylinder Stroke Hub Corsa cilindro Course du vérin			
RC	...	1120	1122	...	Rod with rod end style "G" Kolbenstange mit Kolbenstangenende "G" Stelo con terminale "G" Tige avec extrémité "G"	6	
RC	...	1121	1123	...	Rod with rod end style "I" Kolbenstange mit Kolbenstangenende "I" Stelo con terminale "I" Tige avec extrémité "I"		
RC	...	1110	1112	...	Rod with rod end style "A" Kolbenstange mit Kolbenstangenende "A" Stelo con terminale "A" Tige avec extrémité "A"		
RC	...	1111	1113	...	Rod with rod end style "H" Kolbenstange mit Kolbenstangenende "H" Stelo con terminale "H" Tige avec extrémité "H"		
RC	...	1130	1131	...	Rod with rod end style "F" Kolbenstange mit Kolbenstangenende "F" Stelo con terminale "F" Tige avec extrémité "F"		
RC	...	1550	1552	A	Magnetic Rod-Piston group with rod end style "G" Gruppe Kolben-Stange mit Kolbenstangenende "G", magnetisch Stelo-pistone magnetico con terminale "G" Tige-piston magnétique avec extrémité "G"	2+3+4+6	
RC	...	1551	1553	A	Magnetic Rod-Piston group with rod end style "I" Gruppe Kolben-Stange mit Kolbenstangenende "I", magnetisch Stelo-pistone magnetico con terminale "I" Tige-piston magnétique avec extrémité "I"		
RC	...	1530	1532	A	Magnetic Rod-Piston group with rod end style "A" Gruppe Kolben-Stange mit Kolbenstangenende "A", magnetisch Stelo-pistone magnetico con terminale "A" Tige-piston magnétique avec extrémité "A"		
RC	...	1531	1533	A	Magnetic Rod-Piston group with rod end style "H" Gruppe Kolben-Stange mit Kolbenstangenende "H", magnetisch Stelo-pistone magnetico con terminale "H" Tige-piston magnétique avec extrémité "H"		
RC	...	1570	1571	A	Magnetic Rod-Piston group with rod end style "F" Gruppe Kolben-Stange mit Kolbenstangenende "F", magnetisch Stelo-pistone magnetico con terminale "F" Tige-piston magnétique avec extrémité "F"	2+4+6	
RC	...	1560	1562	A	Non-magnetic Rod-Piston group with rod end style "G" Gruppe Kolben-Stange mit Kolbenstangenende "G", normal Stelo-pistone non magnetico con terminale "G" Tige-piston non magnétique avec extrémité "G"		
RC	...	1561	1563	A	Non-magnetic Rod-Piston group with rod end style "I" Gruppe Kolben-Stange mit Kolbenstangenende "I", normal Stelo-pistone non magnetico con terminale "I" Tige-piston non magnétique avec extrémité "I"		
RC	...	1540	1542	A	Non-magnetic Rod-Piston group with rod end style "A" Gruppe Kolben-Stange mit Kolbenstangenende "A", normal Stelo-pistone non magnetico con terminale "A" Tige-piston non magnétique avec extrémité "A"		
RC	...	1541	1543	A	Non-magnetic Rod-Piston group with rod end style "H" Gruppe Kolben-Stange mit Kolbenstangenende "H", normal Stelo-pistone non magnetico con terminale "H" Tige-piston non magnétique avec extrémité "H"		
RC	...	1580	1581	A	Non-magnetic rod-piston group with rod end style "F" Gruppe Kolben-Stange mit Kolbenstangenende "F", normal Stelo-pistone non magnetico con terminale "F" Tige-piston non magnétique avec extrémité "F"		
					Rods for cylinder with clamping "F", front flange Kolbenstangen für Zylinder mit Befestigungsart "F", Flansch vorne Steli per cilindro con fissaggio "F", flangia anteriore Tiges pour vérin avec fixation "F", bride avant		
					Rods for cylinder with any clamping except front flange "F" Kolbenstangen für alle Befestigungsarten - mit Ausnahme "F", Flansch vorne Steli per cilindro con qualsiasi fissaggio, eccetto flangia anteriore "F" Tiges pour vérins avec toute fixations, sauf bride avant "F"		
MSU4	Magnetic switch with fixing bracket Magnetendschalter mit Befestigung Sensore magnetico con staffa Détecteur magnétique avec bride					1	

NOTES: The minimum cylinder stroke for two switches is 65 mm
 NOTE: La corsa minima del cilindro per due sensori è di 65 mm

ACHTUNG: Der minimale Hub für Zylinder mit zwei Endschalter ist 65 mm
 NOTE: PL a course minimum du vérin pour deux détecteurs est de mm 65

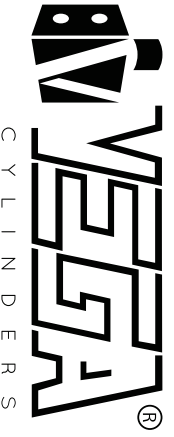

A series of 18 vertical lines spanning the width of the page, providing a template for writing or drawing.