



ТОВ "Компанія "Парк" - офіційний представник в Україні!

+38 (093) 033-33-66
info@parkgroup.com.ua
www.parkgroup.com.ua



V215CD

V215CD

EN

UNI-ISO 6020-2 :1993 Compact Norms Tie Rod Cylinders for Die-Casting Applications

DE

UNI-ISO 6020-2 :1993 Kompakte Zugankerzylinder für Druckgussanwendungen

IT

Cilindri oleodinamici a tiranti a norme UNI-ISO 6020-2 :1993 Compact per pressofusione

FR

Vérins hydrauliques à tirants UNI-ISO 6020-2 : 1993 Compact pour moulage sous pression

215
BAR



Die Casting
Aluminiumdruckgießformen
Pressofusione di alluminio
Moulage sous-pression

CYLINDERS

EN

ORDER CODE

DE

BESTELLCODE

IT

CODICE ORDINE

FR

CODE COMMANDE

Cylinder Model
Zylinder Modell
Modello cilindro
Modèle du vérin

CD

Bore
Bohrung
Alésaggio
Alésage

050

Rod
Kolbenstange
Stelo
Tige

036

Clamping Style
Befestigungs Art
Fissaggio
Fixation

C

Cushioning Type
Endlagendämpfung Typ
Tipo di ammortizzo
Type d'amortissement

0

Oil Ports Type
Art der Anschlüsse
Tipo di orifici
Type d'orifice

G

Oil Ports Position
Lage der Leitungsanschlüsse
Posizione orifici
Position des orifices

G

PAGE SEITE PAGINA PAGE

D6

D6

D8 > D9

D10

D10

D11

V215CD

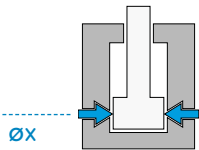
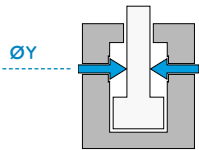

ØX

050

ØY

022

028

036

063

028

036

045

080

036

045

056

100

045

056

070

125

056

070

090

160

070

110

200

090

140

C MX5

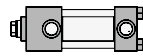

D ME5

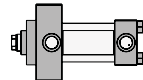

G MS2

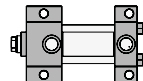

0

1

2

3

4

5

6

G

BSP Thread (Gas)

BSP (Gas) Gewinde

Filetto BSP (Gas)

Filetage BSP (Gas)

N

NPT Thread

NPT Gewinde

Filetto NPT

Filetage NPT

M

Metric Thread

Metrisches Gewinde

Filetto metrico

Filetage métrique

A

B

C

D

E

G

H

I

L

M

N

O

P



Q

T

U

Rod end Type Kolbenstangen Ausführung Estremità stelo Extrémité de la tige	Fluid Type Fluidart Tipo di fluido Type de fluide	Cylinder Version Zylinder-Version Versione cilindro Version du vérin	Stroke Hublänge Corsa Course	Rod Accessories Zubehör Kolbenstange Accessori stelo Accessoires de la tige	Magnetic Switches \ Switch Qty Magnetischer Sensor \ Anzahl der Sensoren Sensori magnetici \ Q.tà sensori DéTECTEURS magnétiques \ Q.té détecteurs
G	H	I	100 +	MFAS27X300 \	MSU1 \ 2

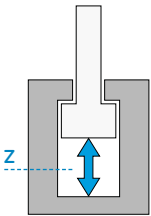
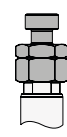
D12 > D13 **D14** **D15** **D7** **D16** **D17**

G Female Metric Thread Metrisches Innengewinde Filetto femmina metrico Taradage métrique	H Water glycol compatible seals Wasserglykolkompatible Dichtungen Guarnizioni compatibili con acqua e glicole Joints compatibles avec l'eau glycolée	M Cylinder with Magnetic Preset Zylinder mit Magnet Cilindro con predisposizione magnetica Vérin avec prédisposition magnétique	Z 	# None Ohne Nessuno Aucun	# \ # None Ohne Nessuno Aucun
A Male Metric Thread Metrisches Aussengewinde Filetto maschio metrico Filetage métrique	V Oil compatible seals Ölkompatible Dichtungen Guarnizioni compatibili con olio Joints compatibles avec l'huile	N Cylinder without Magnetic Preset Zylinder ohne Magnet Cilindro senza predisposizione magnetica Vérin sans prédisposition magnétique	MFAS 	MSU1 \ 1 MSU1 \ 2 Magnetic Switches Magnetische Endschalter Sensori magnetici DéTECTEURS magnétiques	
F Floating Joint Hammerkopf Testa a martello Tenon		Q With 80 °C Mechanical Switches and Control Shaft Joining Bracket Mit 80°C mechanische Endschalter und Verbindung mit Schaltstange Con micro meccanici 80 °C e rinvio stelo-asta Avec détecteurs mécaniques et renvoi de tige - jusque 80°C	DFAS 	MSU1 \ 1 MSU1 \ 2 Magnetic Switches Magnetische Endschalter Sensori magnetici DéTECTEURS magnétiques	
I UNF-UNEF Female Thread (U.S.A. Standard) UNF-UNEF Innengewinde (U.S.A. Standard) Filetto femmina UNF-UNEF (Standard U.S.A.) Taradage UNF-UNEF (Standard U.S.A.)		T With 180 °C Mechanical Switches and Control Shaft Joining Bracket Mit 180°C mechanische Endschalter und Verbindung mit Schaltstange Con micro meccanici 180 °C e rinvio stelo-asta Avec détecteurs mécaniques et renvoi de tige - jusque 180°C	DFAS 		
H UNF-UNEF Male Thread (U.S.A. Standard) UNF-UNEF Aussengewinde (U.S.A. Standard) Filetto maschio UNF-UNEF (Standard U.S.A.) Filetage Male UNF-UNEF (Standard U.S.A.)		I With 80 °C PNP Inductive Switches and control shaft joining bracket Mit 80 °C PNP Induktiveschaltern und Verbindung mit Schaltstange Con micro induttivi PNP 80 °C e rinvio stelo-asta Avec détecteurs inductifs PNP et renvoi de tige - jusque 80 °C			

V215CD

EN

TECHNICAL AND WORKING CHARACTERISTICS CHART

DE

TABELLE TECHNISCHE MERKMALE UND FUNKTION

IT

TABELLA CARATTERISTICHE TECNICHE E DI FUNZIONAMENTO

FR

TABLEAU DES CARACTÉRISTIQUES TECHNIQUES ET DE FONCTIONNEMENT

V215CD

	Maximum Working Pressure Maximale Druck Pressione massima di esercizio Pression maximale d'exercice			
	Versions M Versionen M Versioni M Versions M		Versions N, Q, T, I Versionen N, Q, T, I Versioni N, Q, T, I Versions N, Q, T, I	
	Without Cushioning Ohne Endlagendämpfung Non ammortizzato Sans amortissement	With Cushioning Mit Endlagendämpfung Ammortizzato Avec amortissement	Without Cushioning Ohne Endlagendämpfung Non ammortizzato Sans amortissement	With Cushioning Mit Endlagendämpfung Ammortizzato Avec amortissement
ØX	MPa - (bar) - PSI	MPa - (bar) - PSI	MPa - (bar) - PSI	MPa - (bar) - PSI
50	21,5 - (215) - 3117	18,5 - (185) - 2682	21,5 - (215) - 3117	18,5 - (185) - 2682
63	21,5 - (215) - 3117	18,5 - (185) - 2682	21,5 - (215) - 3117	18,5 - (185) - 2682
80	20 - (200) - 2900	17 - (170) - 2465	20 - (200) - 2900	17 - (170) - 2465
100	19 - (190) - 2755	16 - (160) - 2320	19 - (190) - 2755	16 - (160) - 2320
125	19 - (190) - 2755	16 - (160) - 2320	19 - (190) - 2755	16 - (160) - 2320
160	18,5 - (185) - 2682	15,5 - (155) - 2247	18,5 - (185) - 2682	15,5 - (155) - 2247
200	-	-	17 - (170) - 2465	14 - (140) - 2030

ØX = Bore Bohrung Alesaggio Alésage

Maximum Nominal Delivery (Pushing) Nennwert Max. Durchflussmenge (beim Ausfahren) Portata max. nominale Débit nominal maximum (en poussée)		Maximum Piston Speed Maximale Geschwindigkeit des Kolbens Velocità massima pistone Vitesse maximum du vérin		Maximum Working Temperature Max. Betriebstemperatur Temperatura max. esercizio Température max. d'exercice	
Without Cushioning Ohne Endlagendämpfung Non ammortizzato Sans amortissement		With Cushioning Mit Endlagendämpfung Ammortizzato Avec amortissement		Without Cushioning Ohne Endlagendämpfung Non ammortizzato Sans amortissement	
Without Cushioning Ohne Endlagendämpfung Non ammortizzato Sans amortissement		With Cushioning Mit Endlagendämpfung Ammortizzato Avec amortissement		Versions M, Q, I Versionen M, Q, I Versioni M, Q, I Versions M, Q, I	
Without Cushioning Ohne Endlagendämpfung Non ammortizzato Sans amortissement		With Cushioning Mit Endlagendämpfung Ammortizzato Avec amortissement		Versions N, T Versionen N, T Versioni N, T Versions N, T	
ØX	l/min	l/min	m/s	m/s	
50	10	90	0,1	0,8	80 °C 176 °F
63	18	140	0,1	0,8	
80	30	180	0,1	0,8	
100	45	280	0,1	0,8	
125	70	290	0,1	0,8	
160	120	480	0,1	0,8	
200	180	750	0,1	0,8	

EN

BORE, ROD SIZE AND STROKE

DE

KOLBEN, STANGE UND HUBLÄNGE

IT

ALESAGGIO, DIAMETRO STELO E CORSA

FR

ALÉSAGE, DIAMÈTRE DE TIGE ET COURSE

CD

ØX

050

ØY

036

C

0

G

G

Table for push and pull forces in daN (1 daN = 1 kgf)

Tabelle Druck- und Zugkraft in daN (1 daN=1 kgf)

Tabella forze in spinta e tiro in daN (1 daN = 1 kgf)

Tableau des forces de Poussée et de traction en daN (1 daN=1 kgf)

ØX	ØY	8 MPa 80 bar 1160 PSI		10 MPa 100 bar 1450 PSI		12,5 MPa 125 bar 1812 PSI		16 MPa 160 bar 2320 PSI		20 MPa 200 bar 2320 PSI	
		Th	Tr	Th	Tr	Th	Tr	Th	Tr	Th	Tr
050	022		1266		1583		1978		2532		3165
	028	1570	1078	1963	1347	2453	1684	3140	2155	3925	2694
	036		756		945		1181		1512		1890
063	028		2000		2500		3125		4000		5000
	036	2493	1679	3116	2099	3895	2623	4985	3357	6231	4197
	045		1221		1526		1908		2442		3052
080	036		3205		4007		5008		6411		8013
	045	4019	2748	5024	3435	6280	4294	8038	5495	10048	6869
	056		2050		2562		3203		4100		5124
100	045		5008		6260		7825		10017		
	056	6280	4311	7850	5389	9813	6736	12560	8621		
	070		3203		4004		5004		6406		
125	056		7843		9804		12261		15694		
	070	9813	6735	12266	8419	15333	10529	19635	13477		
	090		4726		5908		7388		9456		
160	070	16077	13000	20096	16250	25120	20312	32154	25999		
	110		8478		10598		13247		16956		
200	090	25120	20033	31400	25042	39250	31302	50240	40067		
	140		12811		16014		20018		25623		

Th Thrust Druck Spinta Poussée

ØX Bore Bohrung Alesaggio Alésage

Tr Traction Zug Trazione Traction

ØY Rod Kolbenstange Stelo Tige

NOTES: Bore 200 is available only for the non-magnetic version and with a minimum delivery time of 6 weeks. Maximum pressure for bores bigger than 80 mm will tend to decrease. Before choosing the bore, see table at page D4.

ACHTUNG: Bohrung 200 mm nur in NICHT-magnetischer Ausführung und mit minimaler Lieferzeit von 6 Wochen. Der maximal zulässige Betriebsdruck nimmt bei Bohrungen über 80 mm ab. Bei Auswahl der Bohrung Tabelle auf Seite D4 beachten.

NOTE: L'alesaggio 200 è disponibile solo in versione non magnetica e con tempo di consegna minimo di 6 settimane. La pressione massima per gli alesaggi superiori a 80 mm tende a scendere. Prima di scegliere l'alesaggio vedere la tabella a pagina D4.

NOTE: Alésage 200 disponible seulement en version non magnétique sous un délai de 6 semaines. La pression maximum pour alésages supérieurs à 80 mm se réduit. Avant de choisir l'alésage voir la table à la page D4.

G H I **Z** 100 + MFAS27X300 \ MSU1 \ 2

Standard and Recommended Strokes in mm

Standard und empfohlene Hublängen in mm

Corse standard e raccomandate in mm

Courses standards et Recommandées en mm

Z	020	050	080	100	125	160	200	250
ØX								
50								
63								
80								
100								
125								
160								
200								

V215CD

 Standard strokes Standard hublängen Corse standard Course standard

 Special strokes Sonderhublängen Corse speciali Courses especiales

 ØX Bore Bohrung Alesaggio Alésage

 Z Stroke Hub Corsa Course

NOTES: Any stroke can be supplied on request with the same delivery time. For strokes shorter than 80 mm, consider our compact cylinders series V250CE and V450CM as an alternative. For special strokes, you might use a guide spacer (for ordering, contact our technical department). Stroke tolerance $-0/+0,5$ mm.

ACHTUNG: Jede Hublänge ist auf Anfrage lieferbar, bei entsprechender Lieferzeit. Bei Hublängen unter 80mm können alternativ die Zylinder der KOMPAKT-Baureihen V250CE und V450CM in Betracht gezogen werden. Für Sonderhublängen können Distanzscheiben eingesetzt werden (Abteilung Technik kontaktieren). Toleranz Hublänge: $-0/+0,5$ mm.

NOTE: Qualunque corsa può essere fornita su richiesta con analogo tempo di consegna. Per corse inferiori ad 80 mm, considerare in alternativa i cilindri compatti serie V250CE e V450CM. Per le corse speciali valutare l'utilizzo di distanziale di sovra-guida (per l'ordine, contattare il nostro ufficio tecnico). Tolleranza sulla corsa $-0/+0,5$ mm.

NOTE: Quelconque course peut être fournie sur demande avec le même délai. Pour les courses inférieures à 80 mm considérer en alternative les vérins blocs série V250CE et V450CM. Pour les course spéciales envisager l'utilisation d'une bride de surguidage (contacter notre service technique). Tolérance course $-0/+0,5$ mm.

EN

CHOICE OF CLAMPING STYLE

DE

AUSWAHL BEFESTIGUNGSART

IT

SCELTA DEL FISSAGGIO

FR

CHOIX DE LA FIXATION

CD

 $\varnothing X$ $\varnothing Y$

050

036

C

0

G

G

C

Base Clamping Style ISO MX5

Grundausführung ISO MX5

Fissaggio Base ISO MX5

Fixation base ISO MX5

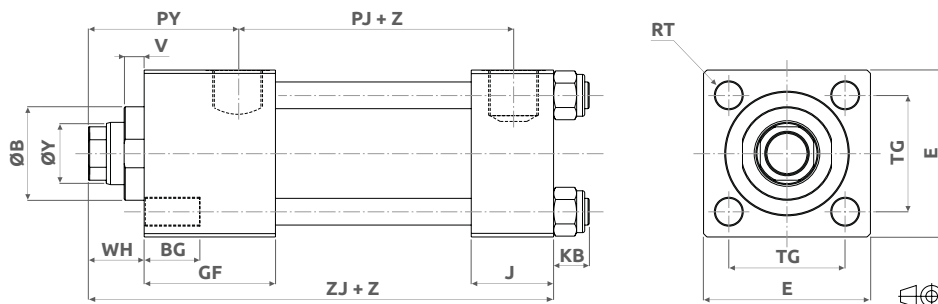
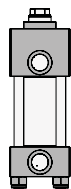

D

Head Flange ISO ME5

Flansch vorne ISO ME5

Flangia anteriore ISO ME5

Bride avant ISO ME5

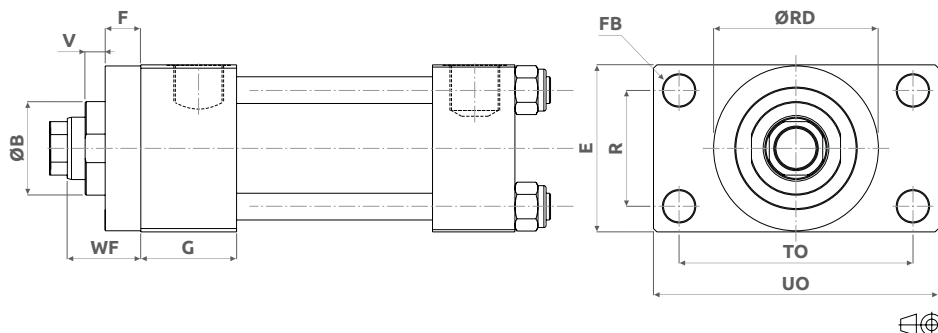
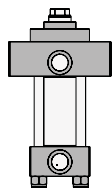

V215CD

$\varnothing X$	$\varnothing Y$	$\varnothing B$ f 9	BG	E	F	FB H 13	G	GF	J	KB	PY	PJ+	R js 12	$\varnothing RD$ f 8	RT	TG js 12	TO js 12	UO	V	WF	WH	ZJ+
	22	34												74								
50	28	42	25	75	16	14	43	59	37	16	67	74	52	74	M12x1,75	52,3	105	128	9	41	25	159
	36	50												74								
	28	42												75					11			
63	36	50	25	90	16	14	43	59	37	16	71	80	65	75	M12x1,75	64,3	117	142	12	48	32	167
	45	60												88					13			
	36	50												82					9			
80	45	60	30	115	20	18	49	69	44	20	77	93	83	82	M16x2	82,7	149	180	9	51	31	190
	56	72												105					9			
	45	60												92					9			
100	56	72	30	130	22	18	50	72	45	20	82	101	97	92	M16x2	96,9	162	190	10	57	35	203
	70	88												125					10			
	56	72												105					10			
125	70	88	30	165	22	22	56	78	55	26	86	117	126	125	M22x2,5	125,9	208	247	10	57	35	232
	90	108												150					10			
	70	88												125					7	57	32	243
160	110	133	30	205	22	26	56	81	58	33	86	130	155	170	M27x3	154,9	253	297	7	57	32	243
	90	108												150					7	57	32	301*
200	140	163	40	245	25	33	76	101	76	35	98	165	190	210	M30x3,5	190,2	300	347	7	57	32	301*

NOTES: For dimensions where no tolerance is indicated, refer to DIN norm 7168-m.

ACHTUNG: Für Maße ohne Toleranzangaben gilt DIN 7168-m.

NOTE: Per le dimensioni senza indicazione di tolleranza, riferirsi alla norma DIN 7168-m.

NOTE: Pour les dimensions où la tolerance n'est pas indiquée, adressez-vous aux normes DIN 7168-m.

*: Not per UNI-ISO 6020/2

Entspricht nicht UNI-ISO 6020/2

Non secondo UNI-ISO 6020/2

Non pour UNI-ISO 6020/2

ØX = Bore Bohrung Alesaggio Alésage

ØY = Rod Kolbenstange Stelo Tige

Z = Stroke Hub Corsa Course

Example Beispiel Esempio Exemple
 ØX = 50, ØY = 36, Z = 200mm : ZJ + Z = 159 + 200 = 359 mm

Z

G H I 100 + MFAS27X300 \ MSU1 \ 2

G

Head and Rear Foot ISO MS2

Doppel Flanschbefestigung seitlich ISO MS2

Piedino anteriore e posteriore ISO MS2

Patte avant et arrière ISO MS2

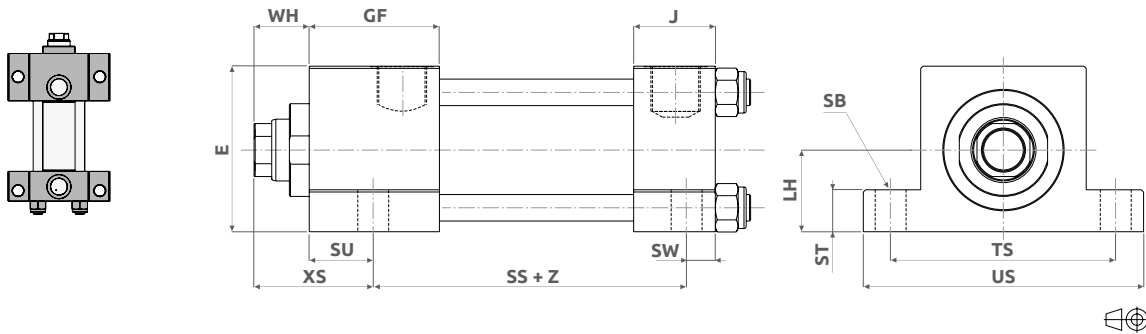

ØX	ØY	E	GF	J	LH ±0,05	ØSB	SS+	ST	SU	SW	TS js 12	US	WH	XS
50	22	75	59	37	37	14	92	19	29	13	102	127	25	54
	28													
63	36	90	59	37	44	18	86	26	33	16	124	160 *	32	65
	45													
80	36	115	69	44	57	18	105	26	37	17	149	186	31	68
	45													
100	56	130	72	45	63	26	102	32	44	22	172	216	35	79
	70													
125	56	165	78	55	82	26	131	32	44	22	210	254	35	79
	90													
160	70	205	81	58	101	33	130	38	54	27	260	318	32	86
	110													
200	90	245	101	76	122	39	172	44	74	23	311	381	32	106
	140													

NOTES: For dimensions where no tolerance is indicated, refer to DIN norm 7168-m.

ACHTUNG: Für Maße ohne Toleranzangaben gilt DIN 7168-m.

NOTE: Per le dimensioni senza indicazione di tolleranza, riferirsi alla norma DIN 7168-m.

NOTE: Pour les dimensions où la tolerance n'est pas indiquée, adressez-vous aux normes DIN 7168-m.

* : Within ISO 6020/2

Entspricht ISO 6020/2

Rientra nella ISO 6020/2

Respecte la norme ISO 6020/2

V215CD

CD

ØX

050

ØY

036

C

0

G

G

Cylinder Cushioning Endlagendämpfung Zylinders Ammortizzo del cilindro Amortissement du vérin

Cushioning Type Endlagendämpfung Typ Tipo di ammortizzo Type d'amortissement

Cushioning Type	Endlagendämpfung Typ	Tipo di ammortizzo	Type d'amortissement
0	Without cushioning and air bleed Senza ammortizzo e sfiato aria		Ohne Dämpfung und Entlüftung Sans amortissement et purge
1	Head cushioning and air bleed Ammortizzo e sfiato anteriore		Dämpfung und Entlüftung am Zylinderkopf Amortissement et purge avant
2	Rear cushioning and air bleed Ammortizzo e sfiato posteriore		Dämpfung und Entlüftung am Zylinderboden Amortissement et purge arrière
3	Head and rear cushioning and air bleed Ammortizzo e sfiato anteriore e posteriore		Beidseitige Endlagendämpfung und Entlüftung Amortissement et purge avant et arrière
4	Head air bleed Sfiato aria anteriore		Vordere Entlüftung Purge avant
5	Rear air bleed Sfiato aria posteriore		Hintere Entlüftung Purge arrière
6	Head and rear air bleed Sfiato aria anteriore e posteriore		Beidseitige Entlüftung Purge avant et arrière

Cushioning Length

Länge Endlagendämpfung

Lunghezza ammortizzo

Longueur amortissement

ØX

Head and Rear

Kopf und Boden

Anteriore e posteriore

Avant et arrière

mm

50

~ 20

63

~ 22

80

~ 26

100

~ 26

125

~ 28

160

~ 32

200

~ 35

Type of Ports of the Cylinder Art der Anschlüsse des Zylinders Tipo di orifici del cilindro Type d'orifices du vérin

Type of Ports Art der Anschlüsse Tipo di orifici Type d'orifice

G	BSP Thread (GAS) BSP (Gas) Gewinde Filetto BSP (GAS) Filetage BSP (GAS)
N	NPT Thread (Standard USA) NPT Gewinde (Standard USA) Filetto NPT (Standard USA) Filetage NPT (Standard USA)
M	Metric Thread Metrisches Gewinde Filetto metrico Filetage métrique

ØX	EE		
	BSP	NPT	Metric Metrico Métrique
50	1/2"	1/2"	M22x1,5
63	1/2"	1/2"	M22x1,5
80	3/4"	3/4"	M27x2
100	3/4"	3/4"	M27x2
125	1"	1"	M33x2
160	1"	1"	M33x2
200	1-1/4"	1-1/4"	M42x2

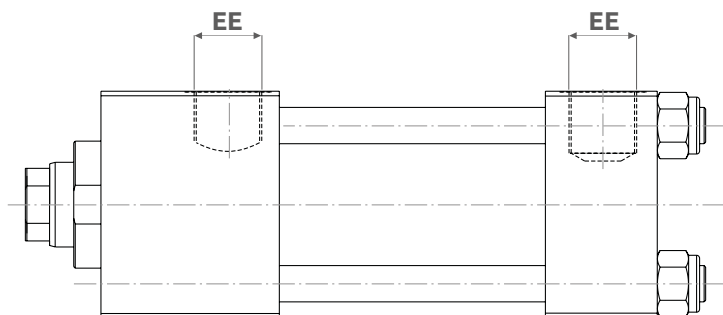

ØX = Bore Bohrung Alesaggio Alésage

G H I Z 100 + MFAS27X300 \ MSU1 \ 2

		H	A	B	C	D	G	I	L	N	O	M	P	Q	T	U	E	H	A	B	C	D	G	I	L	N	O	M	P	Q	T	U	E	H	A	B	C	D	G	I	L	N	O	M	P	Q	T	U	E	
Port Position	Head	1	1	1	1	2	2	2	2	3	3	3	3	4	4	4	4	1	1	1	1	2	2	2	2	3	3	3	3	4	4	4	4	1	1	1	1	2	2	2	2	3	3	3	3	4	4	4	4	
	Rear	1	2	3	4	1	2	3	4	1	2	3	4	1	2	3	4	1	2	3	4	1	2	3	4	1	2	3	4	1	2	3	4	1	2	3	4	1	2	3	4	1	2	3	4	1	2	3	4	
Cushioning Screw Position	Head	3	3	3	3	4	4	4	4	1	1	1	1	2	2	2	2	2	2	2	2	4	4	4	4	2	2	4	2	2	2	2	2	3	3	3	3	1	1	1	1	1	1	1	1	1	2	2	2	2
	Rear	3	4	1	2	3	4	1	2	3	4	1	2	3	4	1	2	2	4	2	2	2	4	2	2	2	4	4	2	2	4	2	2	3	1	1	2	3	1	1	2	3	1	1	2	3	1	1	2	
Clamping		C																D																G																

Port Position Lage der Leitungsanschlüsse Posizione Orifizio Position de l'orifice

Cushioning Screw Position Dämpfungseinstellschrauben Posizione vite reg. ammortizzo Position vis regulation amortissement

Rear Boden Posteriori Arrière

Head Kopf Anteriori Avant

Clamping Befestigung Fissaggio Fixation

* : With this configuration, elbow joints cannot be applied and low head clamping screws are required.

Bei dieser Variante können keine Winkelverschraubungen eingesetzt werden.

Con questa configurazione non si possono applicare raccordi a gomito e le viti di fissaggio devono essere a testa ribassata.

Un raccordement avec coude n'est pas possible avec cette configuration.

: Only for version M, N.

Nur für Versionen M, N.

Solo per versioni M, N.

Seulement pour les versions M, N.

Barring special requirements, "H" is the standard configuration.

Sind keine besonderen Anforderungen nötig, ist "H" die Standardkonfiguration.

Se non ci sono particolari esigenze, la configurazione "H" è quella standard.

Sans exigence particulière, la configuration standard est "H".

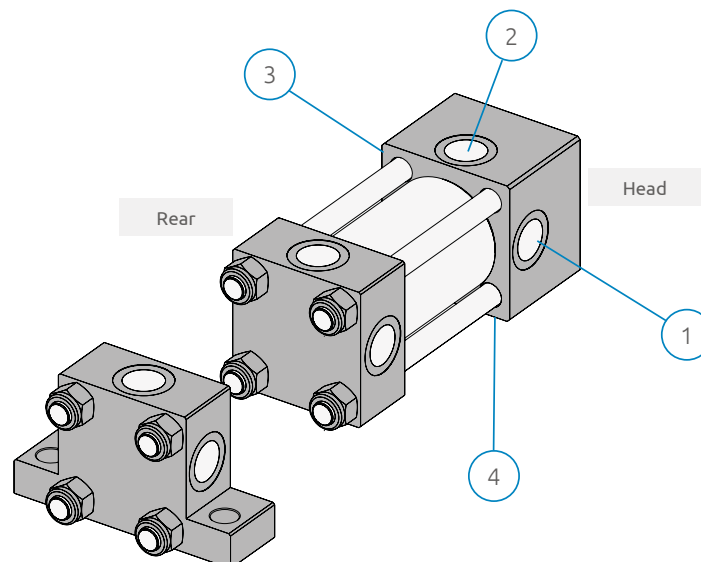

V215CD

EN

CHOICE OF ROD END STYLE

DE

AUSWAHL KOLBENSTANGENENDE

IT

SCELTA DELL' ESTREMITÀ DELLO STELO

FR

CHOIX DE L'EXTRÉMITÉ DE LA TIGE

	ØX	ØY				
CD	050	036	C	0	G	G

Rod End Style Description Beschreibung des Kolbenstangenendes Descrizione tipo di estremità Description du type d'extrémité de la tige

V215CD

G	<p>Female Metric Thread Metrisches Innengewinde Filetto femmina metrico Taraudage métrique</p>
A	<p>Male Metric Thread Metrisches Aussengewinde Filetto maschio metrico Filetage métrique</p>
F*	<p>Floating Joint Hammerkopf Testa a martello Tenon</p>
I	<p>UNF-UNEF Female Thread (U.S.A. Standard) UNF-UNEF Innengewinde (U.S.A. Standard) Filetto femmina UNF-UNEF (Standard U.S.A.) Taraudage UNF-UNEF (Standard U.S.A.)</p>
H	<p>UNF-UNEF Male Thread (U.S.A. Standard) UNF-UNEF Aussengewinde (U.S.A. Standard) Filetto maschio UNF-UNEF (Standard U.S.A.) Filetage Male UNF-UNEF (Standard U.S.A.)</p>

* : Only for version M, N.

Nur für Versionen M, N.

Solo per versioni M, N.

Seulement pour les versions M, N.

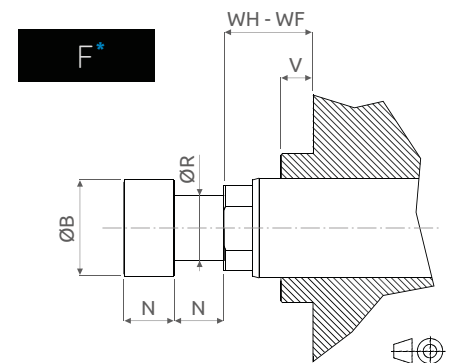
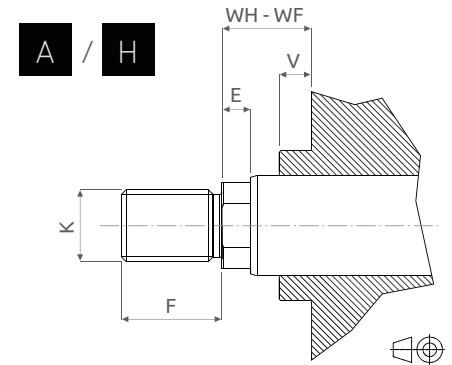
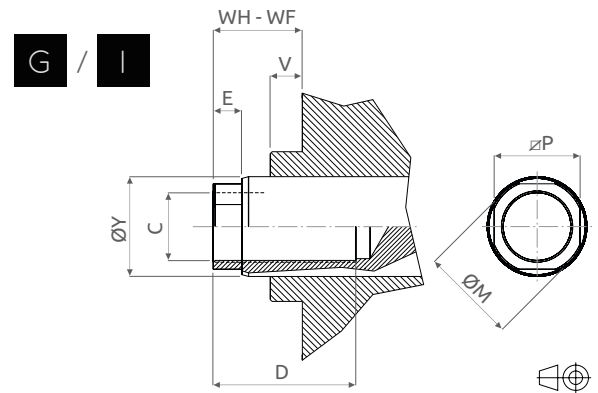

ØX Bore Bohrung Alésaggio Alésage

ØY Rod Kolbenstange Stelo Tige

G

H

I

Z

100

+

MFAS27X300

\

MSU1 \ 2

ØX	ØY	ØB	ØB1	C		D	E	F	K		ØM	N	N1	ØP	ØR	ØR1	S	F1	V	WF*	WH	
				METRIC	UNF-UNEF				METRIC	UNF-UNEF												
	22	21	18	M12x1,75	1/2-20	20	8	22	M16x1,5	5/8-18	21	14	8	18	13	11	-	-				
50	28	27	22	M20x2,5	3/4-16	30	8	28	M20x1,5	3/4-16	27	14	10	24	18	14	M14x1,5	18	9	41	25	
	36	35	28	M27x3	1-12	40	11	36	M27x2	1-12	35	18	12,5	32	21	18	M16x1,5	22				
	28	27	22	M20x2,5	3/4-16	30	8	28	M20x1,5	3/4-16	27	14	10	24	18	14	-	-	11			
63	36	35	28	M27x3	1-12	40	11	36	M27x2	1-12	35	18	12,5	32	21	18	M16x1,5	22	12	48	32	
	45	44	35	M33x3,5	1-1/4-12	50	12	45	M33x2	1-1/4-12	44	22	16	40	33	22	M20x1,5	28	13			
	36	35	28	M27x3	1-12	40	11	36	M27x2	1-12	35	18	12,5	32	21	18	-	-	9			
80	45	44	35	M33x3,5	1-1/4-12	50	12	45	M33x2	1-1/4-12	44	22	16	40	33	22	M20x1,5	28	9	51	31	
	56	54	45	M42x2	1-11/16-18	56	14	56	M42x2	1-11/16-18	54	26	20	50	40	28	M27x2	36	9			
	45	44	35	M33x3,5	1-1/4-12	50	12	45	M33x2	1-1/4-12	44	22	16	40	33	22	-	-	9			
100	56	54	45	M42x2	1-11/16-18	56	14	56	M42x2	1-11/16-18	54	26	20	50	40	28	M27x2	36	10	57	35	
	70	68	56	M48x2	1-7/8-16	63	18	63	M48x2	1-7/8-16	68	34	25	•	50	35	M33x2	45	10			
	56	54	•	M42x2	1-11/16-18	56	14	56	M42x2	1-11/16-18	54	26	•	50	40	•	-	-	10			
125	70	68	•	M48x2	1-7/8-16	63	18	63	M48x2	1-7/8-16	68	34	•	•	50	•	M33x2	45	10	57	35	
	90	88	•	M64x3	2-1/2-16	85	18	85	M64x3	2-1/2-16	88	40	•	•	64	•	M42x2	56	10			
	70	68	•	M48x2	1-7/8-16	63	18	63	M48x2	1-7/8-16	68	34	•	•	50	•	-	-		10	57	32
160	110	108	•	M80x3	3-1/8-16	95	18	95	M80x3	3-1/8-16	108	50	•	•	80	•	M48x2	63				
	90	88	•	M64x3	2-1/2-16	85		85	M64x3	2-1/2-16	88	40	•	•	64	•	-	-		7	57	32
200	140	136	•	M100x3	4-12	112	18	112	M100x3	3-7/8-16	136	55	•	•	95	•	M64x3	85				

V215CD

Dimensions "C" and "P" as per ISO 4395 available upon request

Maße "C" und "P" nach ISO 4395 auf Anfrage

Misure "C" e "P" secondo ISO 4395 su richiesta

Mesures "C" et "P" selon ISO 4395 disponible sur demande

• : 3 equally spaced holes for locking; no wrench flats

Anstelle einer Schlüsselfläche wird die Kolbenstange mit 3 gleichmäßig am Umfang verteilten Löchern gefertigt.

3 fori equidistanti per bloccaggio; senza piano chiave

La tige est réalisée avec 3 trous équidistants et ne comporte pas de plats de serrage

* : Dimension for clamping "D"

Maß für Befestigungsart "D"

Quota per fissaggio "D"

Côte pour fixation "D"

EN FLUID TYPE

DE FLUIDART

IT TIPO DI FLUIDO

FR TYPE DE FLUIDE

	ØX	ØY				
CD	050	036	C	0	G	G



H
Water glycol compatible seals
Wasserglykolkompatible Dichtungen
Guarnizioni compatibili con acqua e glicole
Joints compatibles avec l'eau glycolée

V
Oil compatible seals
Ölkompatible Dichtungen
Guarnizioni compatibili con olio
Joints compatibles avec l'huile

V215CD

G

H

I

z

100

+

MFAS27X300

\

MSU1 \ 2

M

N

Cylinder with magnetic preset (switches not included)

Zylinder zur magnetischen Endlagenabfrage ausgerüstet (jedoch ohne Sensoren)

Cilindro con predisposizione magnetica (sensori non inclusi)

Vérin avec predisposition pour montage des Détecteurs (détecteurs non inclus)

Cylinder without magnetic preset

Zylinder ohne Ausrüstung zur magnetischen Endlagenabfrage

Cilindro senza predisposizione magnetica

Vérin sans prédisposition pour montage des détecteurs

Q

With 80 °C Mechanical Switches and Control Shaft Joining Bracket

Mit 80°C mechanische Endschalter und Verbindung mit Schaltstange

Con micro meccanici 80 °C e rinvio stelo-asta

Avec détecteurs mécaniques et renvoi de tige - jusque 80°C

T

With 180 °C Mechanical Switches and Control Shaft Joining Bracket

Mit 180°C mechanische Endschalter und Verbindung mit Schaltstange

Con micro meccanici 180 °C e rinvio stelo-asta

Avec détecteurs mécaniques et renvoi de tige - jusque 180°C

I

With 80 °C PNP Inductive Switches and control shaft joining bracket

Mit 80 °C PNP Induktiveschaltern und Verbindung mit Schaltstange

Con micro induttivi PNP 80 °C e rinvio stelo-asta

Avec détecteurs inductifs PNP et renvoi de tige - jusque 80 °C

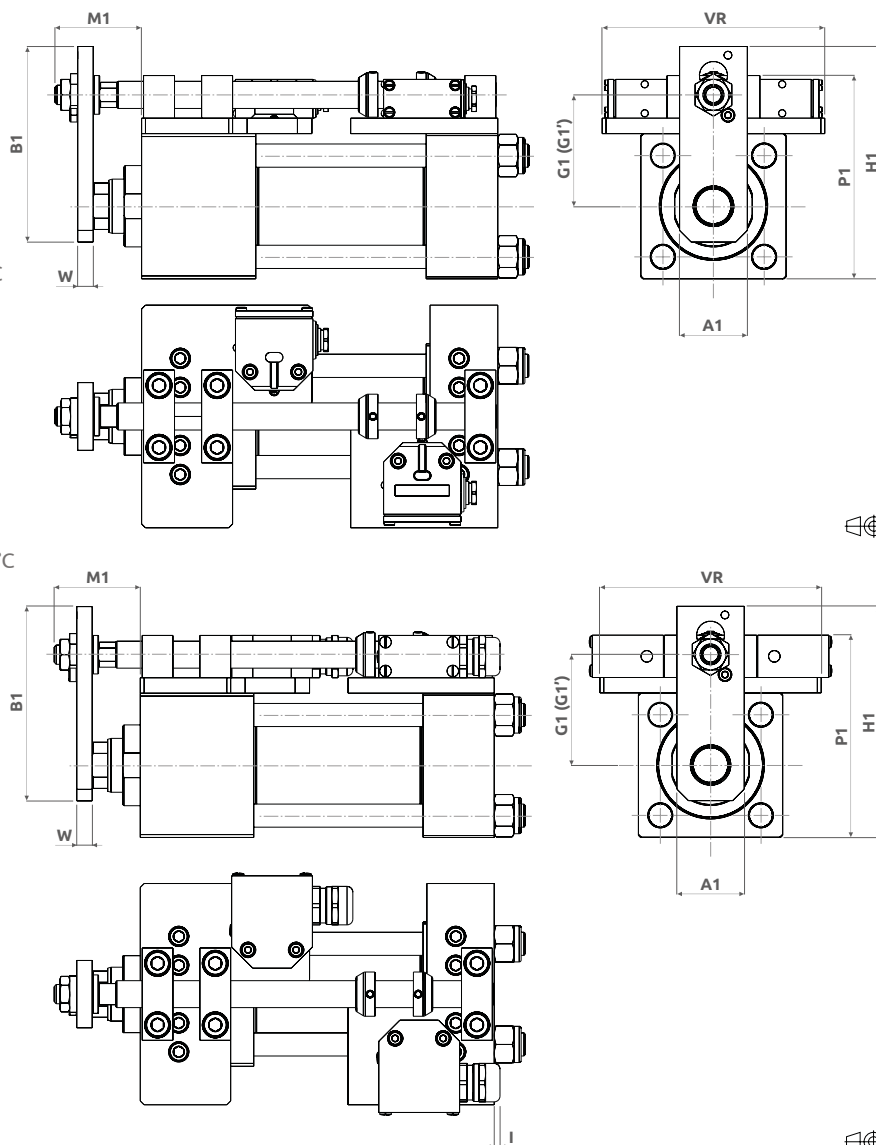

V215CD

ØX	A1	B1	G1	G1' *	H1	I	M1 max	M2 max	P1	VR	W
50	35	101	57,5	-	120	5	51,5	67,5	105	126	8
63	40	112	65	66	135	5	58,5	75,5	120	126	8
80	50	128,5	77,5	-	160	5	59,5	79,5	145	126	10
100	60	142,5	85	87	175	5	65,5	87,5	160	126	12
125	75	164,5	102,5	-	210	5	65,5	87,5	195	126	12
160	90	193,5	122,5	124	250	5	68,5	90,5	235	126	15
200	110	222,5	142,5	-	290	5	68,5	90,5	275	126	15

* : Dimension for clamping "G" Maß für Befestigungsart "G" Quota per fissaggio "G" Côte pour fixation "G"

EN ROD END ACCESSORIES
for male metric thread

IT ACCESSORI STELO
per estremità filetto maschio metrico

DE ZUBEHÖR KOLBENSTANGE
für Aussengewinde metrisch

FR ACCESSOIRES DE LA TIGE
pour extrémité filetée métrique ou UNF

	ØX	ØY				
CD	050	036	C	0	G	G

None Ohne Nessuno Aucun

MFAS 12X175

Floating Joint
High Performance Steel
Hammerkopf
Hochleistungsstahl
Testa a martello
Acciaio ad alte prestazioni
Tenon
Acier haute performance

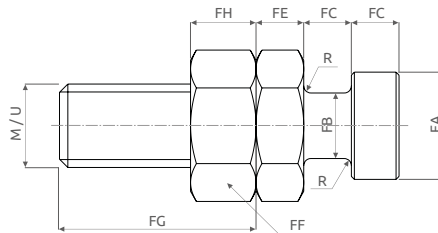
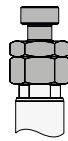

METRIC (G)	UNF-UNEF (I)	ØX	ØY	#1
12X175	1/2-20	50	22	G I
20X250	3/4-16	50	28	G I
27X300	1-12	50	36	G I
20X250	3/4-16	63	28	G I
27X300	1-12	63	36	G I
33X350	1-1/4-12	63	45	G I
27X300	1-12	80	36	G I
33X350	1-1/4-12	80	45	G I
-	-	100	56	- -
33X350	1-1/4-12	100	45	G I
-	-	125	70	- -
-	-	125	56	- -
-	-	160	70	- -
-	-	160	110	- -
-	-	200	090	- -
-	-	200	140	- -

DFAS

Floating Joint With Female
High Performance Steel
Hammerkopf mit Gegenstück
Hochleistungsstahl
Testa a martello con femmina
Acciaio ad alte prestazioni
Tenon avec femelle
Acier haute performance

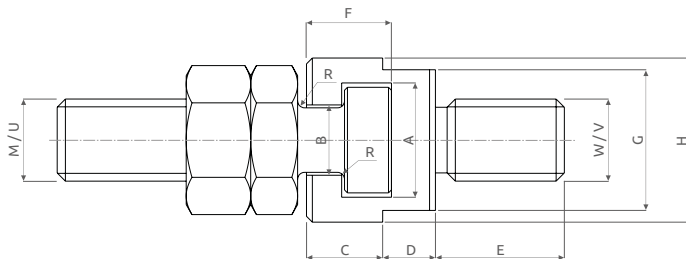
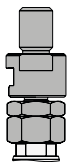

#1 : Compatible rod end code
Kode für passende Ausführung Kolbenstangenende
Cod. estremità stelo compatibile
Cod. extrémité tige compatible

ØX Bore Bohrung Alesaggio Alésage
ØY Rod Kolbenstange Stelo Tige

V215CD

		METRIC		UNF-UNEF		A	B	C	D	E	F	G	H	FA	FB	FC	FE	FF	FG		FH		R
		M	W	U	V														M	U	M	U	
12X175	1/2-20	M12x1,75	M12x1,25	1/2-20	1/2-20	19,5	12	13	9	18	14,5	24	28	18	11	8	7	19	28	28	10	8	1,2
20X250	3/4-16	M20x2,5	M20x1,5	3/4-16	3/4-16	24	15	16	10	28	17,5	30	36	22	14	10	9	30	44	39	16	11	1,2
27X300	1-12	M27x3	M27x2	1-12	1-12	30	19	20	12	40	23	36	44	28	18	12,5	12	36	57	52	22	14	1,5
33X350	1-1/4-12	M33x3,5	M33x2	1-1/4-12	1-5/16-18	39	23	23	14	50	27,5	46	55	35	22	16	14	46	64	64	14	27	2

NOTES: For dimensions where no tolerance is indicated, refer to DIN norm 7168-m. **ACHTUNG:** Für Maße ohne Toleranzangaben gilt DIN 7168-m.
NOTE: Per le dimensioni senza indicazione di tolleranza, riferirsi alla norma DIN 7168-m. **NOTE:** Pour les dimensions où la tolérance n'est pas indiquée, adressez-vous aux normes DIN 7168-m.

EN **MAGNETIC SWITCHES**
usually two for cylinder

IT **SENSORI MAGNETICI**
solitamente due per cilindro

DE **MAGNETSCHALTER**
normalerweise 2 Stück pro Zylinder

FR **DÉTECTEURS MAGNÉTIQUES DE FIN DE COURSE**
usuellement deux par vérin

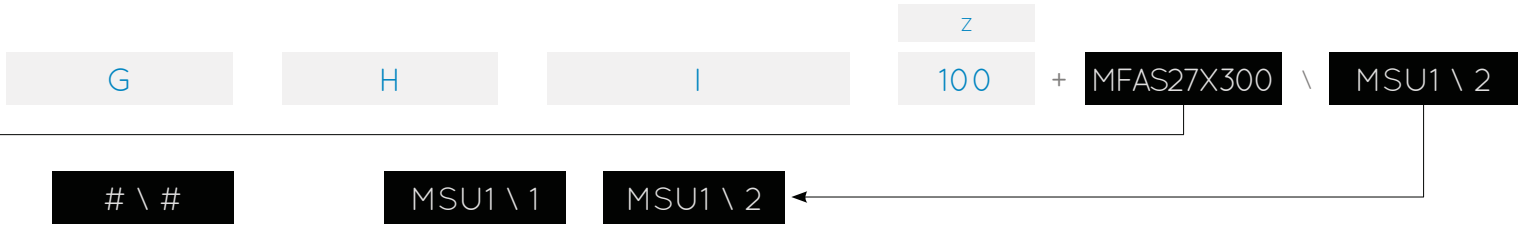

None
Ohne
Nessuno
Aucun

Magnetic Switches
Magnetische Endschalter
Sensori magnetici
DéTECTEURS magnétiques

Switches to be ordered separately from the cylinder
Magnetschalter separat bestellen
Sensori da ordinare separatamente al cilindro
DéTECTEURS a commander séparément du Vérin

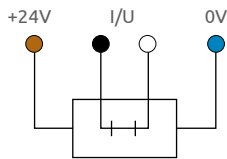

Wire Color Anschlussfarben **Colore conduttori** Couleurs des conducteurs

- Brown** Braun **Marrone** Brun = +24V DC
- Blue** Blau **Blu** Bleu = 0V DC
- Black** Schwarz **Nero** Noir = In/Out **Contact** Kontak **Contacto** Contact
- White** Weiß **Bianco** Blanc = In/Out **Contact** Kontak **Contacto** Contact

I/U = In/Out

Minimum Stroke for Switches Erforderliche Mindesthublänge für Sensoren Corsa minima per sensori Corse minimum pour détecteurs			
ØX	Mounting type Befestigungsart Tipo di montaggio Type de montage		
	1	2	3
mm			
50	45	47	20
63	45	10	20
80	45	10	20
100	45	10	20
125	45	47	20
160	45	10	20

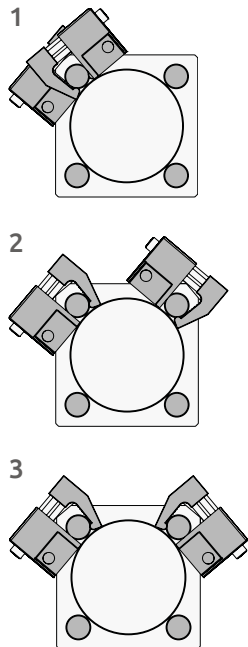

Dimensions (Max.) Aussenabmessungen (max.) Dimensioni ingombro (Max.) Dimensions d'encombrement (Max.)		
ØX	KA	KB
50	16	24
63	13	21,5
80	6,5	14,5
100	10	19,5
125	12	23
160	10	23

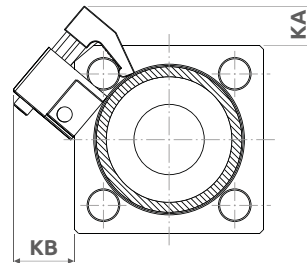

ØX **Bore** Bohrung **Alesaggio** Alésage

V215CD

EN

ACCESSORIES

End Stroke Mechanical and Inductive Micro Switches

IT

ACCESSORI

Micro meccanici e induttivi di fine corsa

DE

ZUBEHÖR

Mechanische und induktive Mikroendschalter

FR

ACCESSOIRES

DéTECTEURS mécaniques et inductifs de fin de course

CD

ØX

ØY

050

036

C

0

G

G

Q

With 80 °C Mechanical Switches and Control Shaft Joining Bracket

Mit 80°C mechanische Endschalter und Verbindung mit Schaltstange

Con micro meccanici 80 °C e rinvio stelo-asta

Avec détecteurs mécaniques et renvoi de tige - jusqu'à 80°C

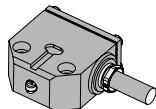

Wire Colour Anschlussfarben

Colore Conduttori Couleurs des Conducteurs

- Common Gemeinsam Comune Commun
- Contact N.C. Kontakt N.C. Contatto N.C. Contact N.F.
- Contact N.O. Kontakt N.O. Contatto N.A. Contact N.O.

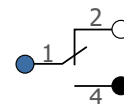

T

With 180 °C Mechanical Switches and Control Shaft Joining Bracket

Mit 180°C mechanische Endschalter und Verbindung mit Schaltstange

Con micro meccanici 180 °C e rinvio stelo-asta

Avec détecteurs mécaniques et renvoi de tige - jusqu'à 180°C

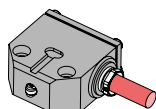

- Common Gemeinsam Comune Commun
- Contact N.C. Kontakt N.C. Contatto N.C. Contact N.F.
- Contact N.O. Kontakt N.O. Contatto N.A. Contact N.O.

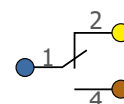

I

With 80 °C PNP Inductive Switches and control shaft joining bracket

Mit 80 °C PNP Induktiveschaltern und Verbindung mit Schaltstange

Con micro induttivi PNP 80 °C e rinvio stelo-asta

Avec détecteurs inductifs PNP et renvoi de tige - jusqu'à 80 °C

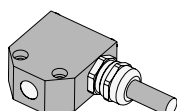

- +24V DC
- Out Aus Uscita Sortie
- 0V DC

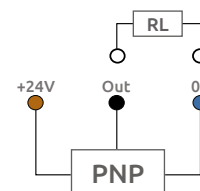

V215CD

Contact Type Art Kontakt Tipo di contatto Type de contact

MS5	MS6	MSI
NO/NC - NA/NC	NO/NC - NA/NC	PNP NA - NO

Voltage Range (from\to) Spannungsbereich (von\bis)

Campo di tensione (da\à) Plage de tension (de\à)

1\250VAC	1\250VAC	10\30VDC
----------	----------	----------

Max Current Max Stromstärke Corrente massima Courant max

2,5A\230VAC\24VDC	2,5A\230VAC\24VDC	130mA
-------------------	-------------------	-------

Max Working Temperature Max Betriebstemperatur

Temperatura max. d'esercizio Température max d'utilisation

80 °C 176 °F	180 °C 356 °F	70 °C 158 °F
-----------------	------------------	-----------------

Mechanical Life Time Mechanische Lebensdauer

Vita meccanica Durée de vie mécanique

10 × 10 ⁶	5 × 10 ⁶	N/A
----------------------	---------------------	-----

Cable Size (Diameter - Length) in mm

Maße Anschlusskabel (Durchmesser - Länge) in mm

Misure cavo (diametro - lunghezza) in mm

Dimensions des fils (diamètre - longueur) en mm

Ø6×3000	Ø6×3000	Ø6×3000
---------	---------	---------

Wires Cross Section Leitungsquerschnitt

Sezione conduttori Section des conducteurs

4x0,25 mm ²	3x0,50 mm ²	3x0,25 mm ²
------------------------	------------------------	------------------------

Degree of Protection Schutzart

Grado di protezione Degré de protection

IP 67 (DIN 40050)	IP 67 (DIN 40050)	IP 67 (DIN 40050)
-------------------	-------------------	-------------------

Dimensions Abmessungen Dimensioni Dimensions

45x44x20	45x40,5x20	54x44x20
----------	------------	----------

Switch Position Adjustment Schaltposition einstellung

Regolazione sensori Ajustement de la position des fin de course

Rear position: -5 mm – Front position for all strokes: min. 5 mm
Position hinten: -5 mm – Position vorne, alle Hübe: min. 5 mm
Posizione indietro: -5 mm – Posizione avanti, tutte le corse: min. 5 mm
Position arrière: -5 mm – Position avant, toutes courses: min. 5 mm

ØX

Bore Bohrung Alesaggio Alésage

EN ACCESSORIES
Thermal insulating plates

IT ACCESSORI
Piastra isolamento termico

DE ZUBEHÖR
Wärmeisolerplatten

FR ACCESSOIRES
Plaques d'isolation thermique

G H I Z 100 + MFAS27X300 \ MSU1 \ 2

RD 050 2700A

Insulating Plate Kit (Head and Cap)

Isolierplatten-Kit (Zylinderkopf und Zylinderboden)

Kit piastra isolante (anteriore e posteriore)

Kit de plaque isolante (avant et arrière)

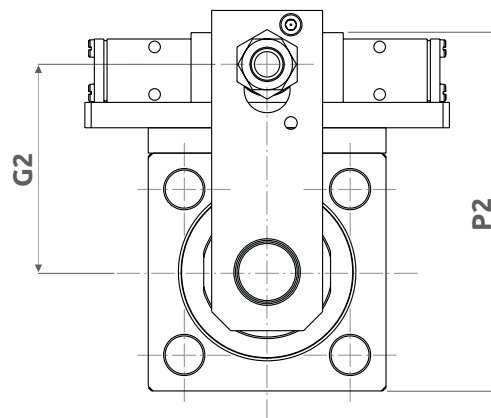
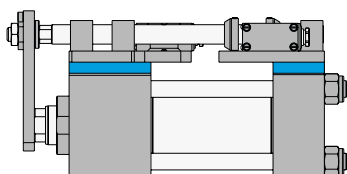

General & technical features Technische Merkmale
Caratteristiche generali Caractéristiques techniques

Max. heat resistance (for short periods) Maximale Spitztemperatur (kurzfristig) 280 °C
Temperatura max. di picco (per breve periodo) Température maxi de pointe (pour une période très brève)

Max. working temperature Maximaler Betriebstemperatur 240 °C
Temperatura max. di esercizio Température maxi de travail

Thermal conductivity Thermische Leitfähigkeit Conduktività termica Conductivité thermique 0,24 W/mk

Compressive strength at 25 °C. Druckfestigkeit bei 25 °C 520 Mpa
Resistenza allo schiacciamento a 25 °C Résistance à la compression à 25 °C

Compressive strength at 200 °C. Druckfestigkeit bei 200 °C 350 Mpa
Resistenza allo schiacciamento a 200 °C Résistance à la compression à 200 °C

Plane parallelism Flächen Parallelität Parallelismo del piano Parallélisme du plan 0,1 mm

NOTES: Average temperature reduction is of 30 °C

NOTE: In media la riduzione di temperatura è di 30 °C

ACHTUNG: Die mittlere Temperatursenkung ist 30 °C

NOTE: La réduction moyenne de température est de 30 °C

ØX	G2	P2
50	67,5	115
63	75	130
80	87,5	155
100	95	170
125	112,5	205
160	132,5	245
200	152,5	285

V215CD

EN

SPARE PARTS

DE

ERSATZTEILE

IT

RICAMBI

FR

RECHANGES

- 1 [Cushioning and air bleed screw with locknut](#)
Einstellschraube Endlagendämpfung und Entlüftung, mit Kontermutter
[Vite reg. ammortizzo e sfiato aria con controdado](#)
Vis de régulation amortissement et purge avec contre écrou

- 2 [Magnetic switch](#) Magnetische Endschalter [Sensore magnetico](#) Détecteur magnétique

- 3 [Magnet](#) Magnet [Magnete](#) Aimant

- 4 [Piston seals](#) Dichtungsset Kolben [Guarnizioni pistone](#) Série joints du piston

- 5 [Piston](#) Kolben [Pistone](#) Piston

- 6 [Tube](#) Zylinderrohr [Camicia](#) Tube

- 7 [Rod](#) Kolbenstange [Stelo](#) Tige

- 8 [Rod seals](#) Dichtungsset Kolbenstange [Guarnizioni stelo](#) Joints de la tige

- 9 [Rod cartridge](#) Führungsbuchse [Cartuccia porta guarnizioni](#) Cartouche de la tige

- 10 [Rod end](#) Kolbenstangenende [Estremità dello stelo](#) Extrémité de la tige

V215CD

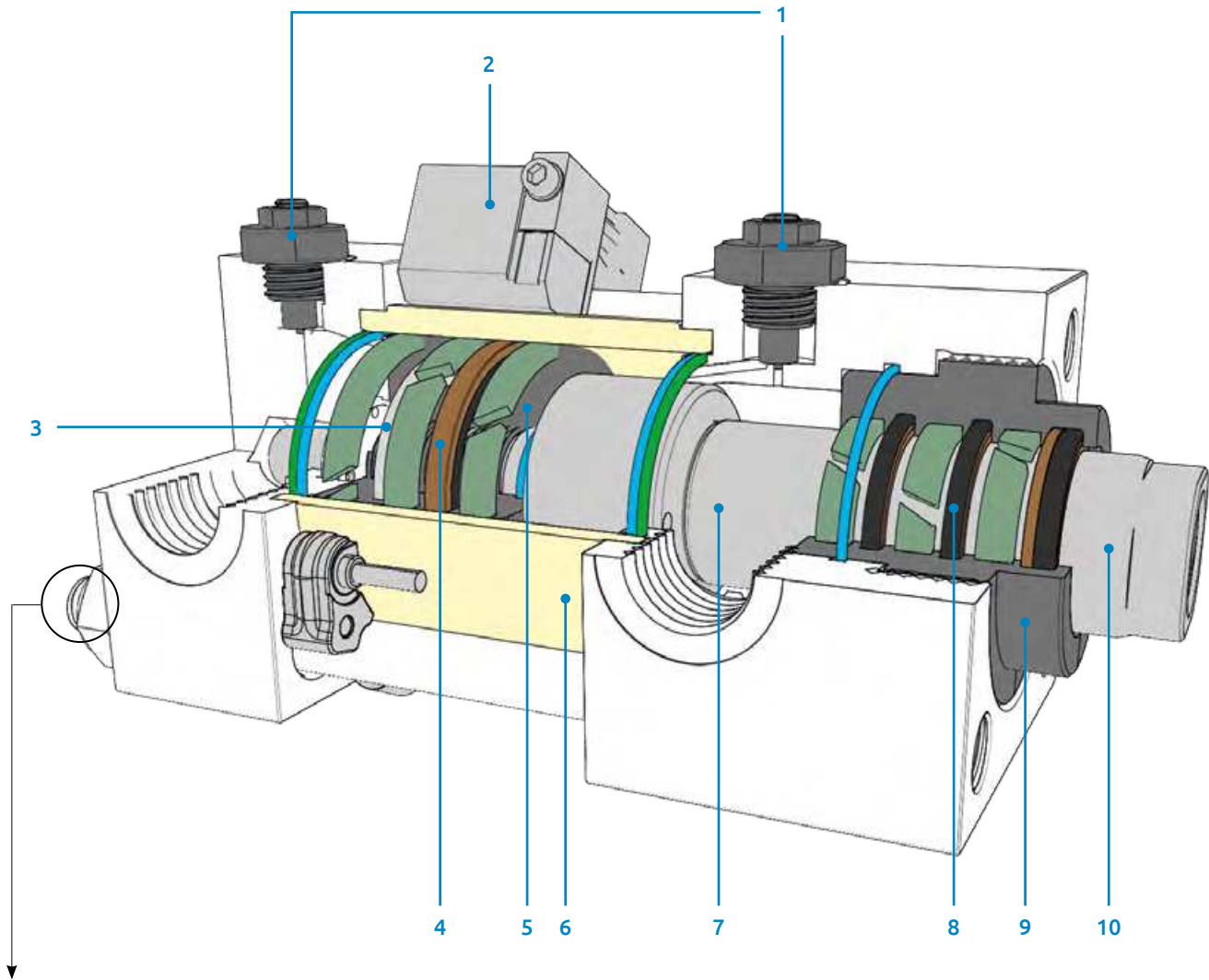

Tightening Torque for Rod Nuts

Anzugsmoment für Mutter

Coppia di serraggio dei dadi per i tiranti

Couple de serrage pour les écrous des tirants

ØX	Nm
50	75
63	75
80	170
100	170
125	400
160	650
200	1150

Type Modell Modello Modèle	Cylinder Bore Zylinder Bohrung Alesaggio cilindro Alésage vérin	Cylinder Rod Zylinder kolbenstange Stelo cilindro Tige du vérin	Article Code Artikelcode Codice articolo Code Article	Additional Set Code Zusätzlicher Kode Indicazione d'assieme Indication d'ensemble	Cylinder Stroke Zylinder Hub Corsa cilindro Course du vérin		
RD	025	012	0310	A			
RD	6020	.		Piston seals kit	Dichtungssatz Kolben Serie guarnizioni pistone Série joints du piston 4
RD	6010	.		Rod seals kit	Dichtungssatz Kolbenstange Serie guarnizioni stelo Série joints de la tige 8
RD	0310	.		Rod cartridge without seals	Führungsbuchse ohne Dichtungen Cartuccia stelo senza guarnizioni Cartouche de la tige sans joints 9
RD	0310	.		Rod cartridge with seals	Führungsbuchse mit Dichtungen Cartuccia stelo con guarnizioni Cartouche de la tige avec joints 8+9
RD	6030	.		Rod seals kit, clamping "D", bore Ø 100 and 160	Dichtungssatz Kolbenstange, Befestigung "D", Bohrung Ø 100 und 160 Serie guarnizioni stelo, fissaggio "D", alesaggio Ø 100 e 160 Série joints de la tige, fixation "D", alésage Ø 100 et 160 8
RD	0330	.		Rod cartridge without seals, clamping "D", bore Ø 100 and 160	Führungsbuchse ohne Dichtungen, Befestigung "D", Bohrung Ø 100 und 160 Cartuccia stelo senza guarnizioni, fissaggio "D", alesaggio Ø 100 e 160 Cartouche de la tige sans joints, fixation "D", alésage Ø 100 et 160 9
RD	0330	.		Rod cartridge with seals, clamping "D", bore Ø 100 and 160	Führungsbuchse mit Dichtungen, Befestigung "D", Bohrung Ø 100 und 160 Cartuccia stelo con guarnizioni, fissaggio "D", alesaggio Ø 100 e 160 Cartouche de la tige avec joints, fixation "D", alésage Ø 100 et 160 8+9
RD	1912	...		Tube for magnetic cylinder	Zylinderrohr für magnetische Ausführung Camicia per cilindro magnetico Tube du vérin magnétique 6
RD	1911	...		Tube for non magnetic cylinder	Zylinderrohr für normale Ausführung Camicia per cilindro non magnetico Tube du vérin non magnétique 6
RD	1510	.		Magnetic piston with seals	Magnetischer Kolben mit Dichtungen Pistone magnetico con guarnizioni Piston pour vérin magnétique avec joints 3+4+5
RD	1512	.		Non-magnetic piston with seals	Kolben mit Dichtungen für nicht magnetische Ausführung Pistone non magnetico con guarnizioni Piston pour vérin non magnétique avec joints 4+5
RD	6050	.		Magnet	Magnet Magnete Aimant 3
RD	2510	.		Screw with locknut for cushioning	Schraube mit Mutter für Dämpfungseinstellung Vite con dado per regolaz. ammortizzo Vis avec écrou pour réglage de l'amortissement 1
RD	6314	...		Complete Mechanical Switch Group, Version "Q"	Bausatz mechanische Endschalter "Q" Kit micro meccanico completo, versione "Q" Kit complet détecteur mécanique, version "Q" 2 > 6
RD	6315	...		Complete Mechanical Switch Group, Version "T"	Bausatz mechanische Endschalter "T" Kit micro meccanico completo, versione "T" Kit complet détecteur mécanique, version "T" 2 > 6
RD	6322	...		Complete Inductive Switch Group, Version "I"	Bausatz Induktiveschalter "I" Kit micro induttivi completo, versione "I" Kit complet détecteur inductifs, version "I" 2 > 6

A	Oil compatible seals	Ölkompatible Dichtungen	Guarnizioni compatibili con olio	Joints compatibles avec l'huile
	H	Water glycol compatible seals	Wasserglykolkompatible Dichtungen	Guarnizioni compatibili con acqua e glicole
	Fluid type	Fluidart	Tipo di fluido	Type de fluide

Type Modell Modello Modèle	Cylinder Bore Zylinder Bohrung Alésaggio cilindro Alésage vérin	Cylinder Rod Zylinder kolbenstange Stelo cilindro Tige du vérin	Article Code Artikelcode Codice articolo Code Article	Additional Set Code Zusätzlicher Kode Indicazione d'assieme Indication d'ensemble	Cylinder Stroke Zylinder Hub Corsa cilindro Course du vérin											
RD	025	012	0310	A		RD	110	Rod without cushioning	Kolbenstange ohne Dämpfung	Stelo non ammortizzato	Tige non amortie	7
RD						RD	113	Rod with cushioning	Kolbenstange mit Dämpfung	Stelo ammortizzato	Tige amortie	7
RD						RD	154	Non-magnetic rod-piston without cushioning	Gruppe Stange-Kolben ohne Dämpfung, normal	Stelo-pistone non magnetico non ammortizzo	Tige-piston non magnétique sans amortissement	4+5+7
RD						RD	156	Non-magnetic rod-piston with rear cushioning	Gruppe Stange-Kolben, Endlagendämpfung am Zylinderboden, normal	Stelo-pistone non magnetico ammortizzo post	Tige-piston non magnétique avec amortissement arrière	4+5+7
RD						RD	155	Non-magnetic rod-piston with head cushioning	Gruppe Stange-Kolben, Endlagendämpfung am Zylinderkopf, normal	Stelo-pistone non magnetico ammortizzo ant.	Tige-piston non magnétique avec amortissement avant	4+5+7
RD						RD	157	Non-magnetic rod-piston with head and rear cushioning	Gruppe Stange-Kolben mit beidseitiger Endlagendämpfung, normal	Stelo-pistone non magnetico ammortizzo ant + post.	Tige-piston non magnétique avec double amortissement	4+5+7
RD						RD	150	Magnetic rod-piston without cushioning	Gruppe Stange-Kolben ohne Dämpfung, magnetisch	Stelo-pistone magnetico non ammortizzo	Tige-piston magnétique sans amortissement	3+4+5+7
RD						RD	152	Magnetic rod-piston with rear cushioning	Gruppe Stange-Kolben mit Endlagendämpfung am Zylinderboden, magnetisch	Stelo-pistone magnetico ammortizzo post.	Tige-piston magnétique avec amortissement arrière	3+4+5+7
RD						RD	151	Magnetic rod-piston with head cushioning	Gruppe Stange-Kolben mit Endlagendämpfung am Zylinderkopf, magnetisch	Stelo-pistone magnetico ammortizzo ant.	Tige-piston magnétique avec amortissement avant	3+4+5+7
RD						RD	153	Magnetic rod-piston with head and rear cushioning	Gruppe Stange-Kolben mit beiseitiger Dämpfung, magnetisch	Stelo-pistone magnetico ammortizzo ant. + post.	Tige-piston magnétique avec double amortissement	3+4+5+7

Fluid type Fluidart Tipo di fluido Type de fluide				
A	Oil compatible seals	Ölkompatible Dichtungen	Guarnizioni compatibili con olio	Joints compatibles avec l'huile
H	Water glycol compatible seals	Wasserglykolkompatible Dichtungen	Guarnizioni compatibili con acqua e glicole	Joints compatibles avec l'eau glycolée

0	Metric male thread "A"	Metrisches Aussengewinde "A"	Filetto maschio metrico "A"	Filetage male métrique "A"	
1	Metric female thread "G"	Metrisches Innengewinde "G"	Filetto femmina metrico "G"	Taraudage métrique "G"	
2	Floating joint "F"	Hammerkopf "F"	Testa a martello "F"	Tenon "F"	10
4	UNF-UNEF male thread "H"	UNF-UNEF Aussengewinde "H"	Filetto maschio UNF-UNEF "H"	Filetage male UNF-UNEF "H"	
5	UNF-UNEF female thread "I"	UNF-UNEF Innengewinde "I"	Filetto femmina UNF-UNEF "I"	Taraudage UNF-UNEF "I"	
6	Floating joint "W"	Hammerkopf "W"	Testa a martello "W"	Tenon "W"	
7	Rod end type on drawing "S"	Spezialausführung "S"	Terminale a disegno "S"	Extrémité de la tige suivant dessin "S"	

Rod end type to be communicated for rod and rod-piston group
 Ausführung des Stangenendes für Stange und Gruppe Stange-Kolben angeben.
Estremità stelo da indicare per stelo e gruppo stelo-pistone.
 L'extrémité de la tige doit être communiquée pour tige et groupe tige-piston



A series of 18 vertical lines spanning the width of the page, providing a guide for writing or drawing.